

OPERATIVE TECHNIQUE

TrueLok™ EVO

Ring Fixation System

TrueLok™ EVO Procallus™ Hybrid System



TrueLok™ EVO

Ring Fixation System

Table of Contents

1	Introduction
2	TL-EVO External Supports
2	TL-EVO Assembly Elements
3	TL-EVO Fixation Elements
4	TL-EVO Ring Templates
4	Procallus Components
6	Equipment Suggested
8	XCaliber Hybrid System Surgical Procedure TL-EVO Ring Application
10	Surgical Procedure for Tibial Plateau Fracture
12	Procallus Application
16	Post Operative Management
16	Frame Removal
16	Mri Safety Information

The surgical technique shown is for illustrative purposes only. The technique(s) actually employed in each case will always depend upon the medical judgment of the surgeon exercised before and during surgery as to the best mode of treatment for each patient. Please kindly refer to the product IFU PQEFS and PQEVO, to the Orthofix implantable devices and related instrument IFU PQSCR, and to the reusable medical devices IFU PQRMD that contain instructions for use of the product.

INTRODUCTION

A Hybrid Fixator provides stability by combining the advantages of tensioned wires and cortical screws. This document describes the application of a Hybrid Fixator on the proximal tibia, but the concept can be also applied on metaphyseal and articular fractures in the distal tibia and the distal femur.



TL-EVO EXTERNAL SUPPORTS

5/8 Rings

5/8 rings are offered in 4 sizes, ranging from 140mm to 200mm. These partial rings can be useful at the joints to extend the range of possible motion while the fixator is applied. 5/8 rings have two sets of quadrant markings, matching the markings found on full rings of the same diameter.

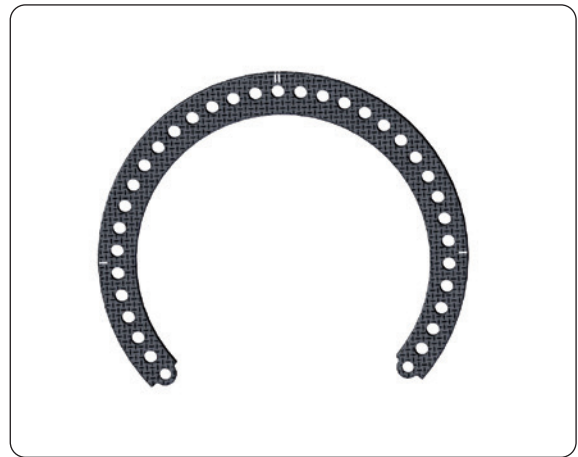

3/8 Rings

3/8 rings are offered in 4 sizes, ranging from 140mm to 200mm. These partial rings can be useful at the joints to extend the range of possible motion while the fixator is applied. 3/8 rings have one set of quadrant markings, matching the markings found on full rings of the same diameter.

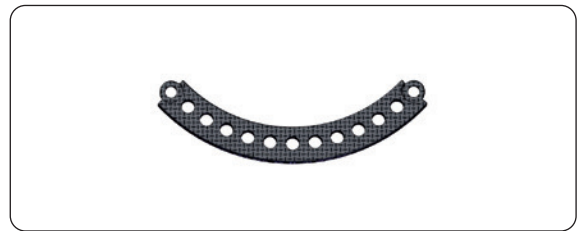

TL-EVO ASSEMBLY ELEMENTS

All TL-EVO assembly elements are made from MRI Conditional stainless steel. Threaded elements have a standard M6 thread and can be adjusted using a 10mm wrench.

TL-EVO BOLTS AND NUTS

Bolts

Bolts are offered in the standard bolt configuration as well as in the Speedbolt Configuration.

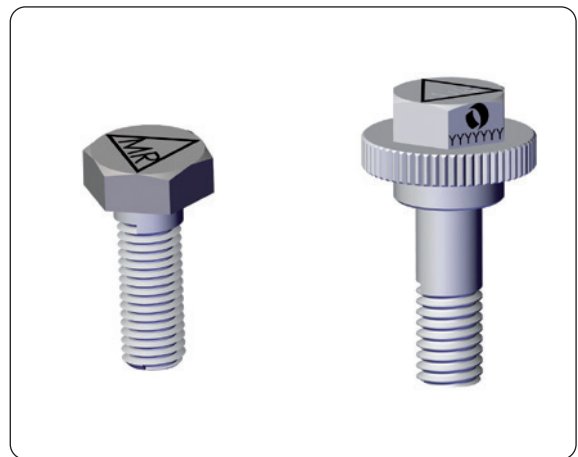

Bolt

Speedbolt

Nuts

Nuts are offered in the standard nut with washer already assembled as well as in the Speednut Configuration.

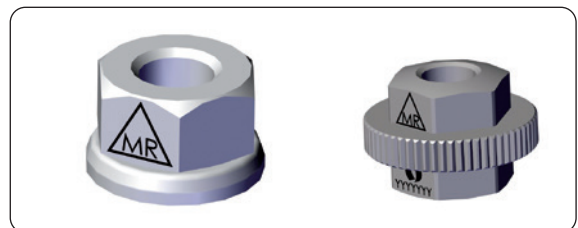

Nut with washer

Speednut

TL-EVO FIXATION ELEMENTS

Wire Fixation Bolt

Wire fixation bolt functions as either a slotted wire fixation bolt or a cannulated wire fixation bolt. The 10mm bolt head is slotted and the bolt neck is cannulated to accept a 1.8mm or 1.5mm wire. The horizontal grooves on the slot and the slotted washer enhance the gripping force on the wire. The washer prevents wire damage to the ring surface.



Wire Fixation Bolt

Half Pin Fixation Bolt

Half pin fixation bolt has a sliding collar fitted over a teardrop shaped opening that provides secure fixation for 4, 5, and 6mm diameter half pins. The sliding collar has a serrated base and scalloped top to enhance the gripping force on the half pin and external support.

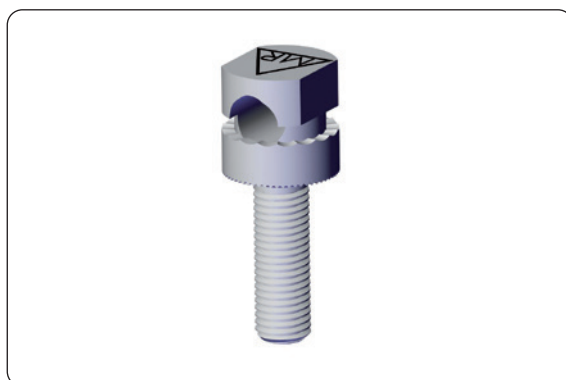

Half Pin Fixation Bolt

8mm Half Pin Fixation Bolt

8mm half pin fixation bolt is an enhanced version of the TrueLok universal half pin fixation bolt. It provides secure fixation for half pins with 5 and 6mm shaft diameters. The 8mm half pin fixation bolt has a turnable collar that allows the insertion of a soft tissue protector. The specific design of the bolt minimizes the tension on the pins during tightening.



8mm Half Pin Fixation Bolt

Hole Posts

Posts are available in three sizes, ranging from 2 to 4 holes. They have a 10mm by 13mm cross section, allowing the surgeon to stabilize them with a 10mm wrench. The posts have a standard female threaded base, allowing them to be secured to an external support by a bolt.



Hole Posts

TL-EVO RING TEMPLATES

Proper ring sizing is essential to prepare the external fixation frame for the treatment of the fracture as required. The surgeon must determine the proper ring size required based on the size of the limb. Use of the TL-EVO templates provides a simple and reliable way to determine the proper ring size.

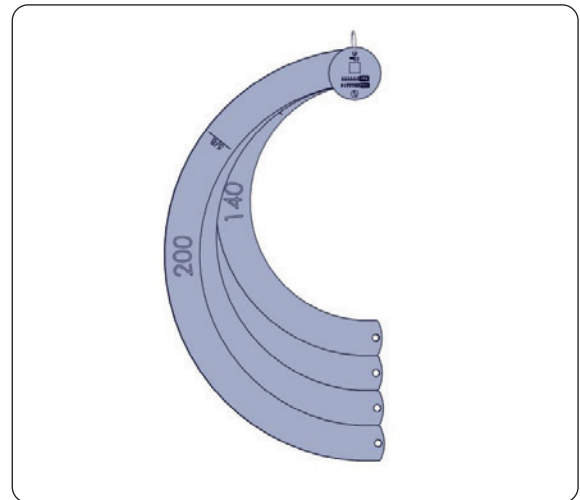

PROCALLUS™ COMPONENTS

ProCallus Fixator Kits

Complete with appropriate Compression-Distraction Unit and Allen Wrench 6mm.

1

90001 Long

(27.6cm between outermost screws when fixator body fully closed: extends by 8cm).



2

90000 Standard

(23.6cm between outermost screws when fixator body fully closed: extends by 4cm).



3

90028 Short

(21.6cm between outermost screws when fixator body fully closed: extends by 2.75cm).



If the fixator is reused, cams and bushes should be replaced.

80022 - ProCallus Fixator Hybrid Connection



90038 Supplementary Screw Holder Clamp



81043 Supplementary Screw Holder Bar Radiolucent

Length 300mm



80042 Posts

Length 50mm



EQUIPMENT SUGGESTED

All TL-EVO elements are provided in sterile pack with the exception of TL-EVO templates (for rings).

SIZING TEMPLATES

Part #	Description
886663	TrueLok Evo Ring And Strut Templates

EXTERNAL SUPPORTS

Part #	Description
5/8 RINGS	
99-882140	Rx 5/8 Modular Ring D140mm Sterile
99-882160	Rx 5/8 Modular Ring D160mm Sterile
99-882180	Rx 5/8 Modular Ring D180mm Sterile
99-882200	Rx 5/8 Modular Ring D200mm Sterile
3/8 RINGS	
99-881140	Rx 3/8 Modular Ring D140mm Sterile
99-881160	Rx 3/8 Modular Ring D160mm Sterile
99-881180	Rx 3/8 Modular Ring D180mm Sterile
99-881200	Rx 3/8 Modular Ring D200mm Sterile

ADDITIONAL COMPONENTS

Part #	Description	Qty
20116735	TL Short Tensioner Tip	2
20116736	Extended Tensioner Tip Assembly	2
20116731	TrueLok System Retaining Tensioner Tip	2
54-1154	TL, Wrench, Combo, 10mm	1
91150	Universal T-Wrench	1
54-2226	TL, 90 Degree Tubular Wrench	1
54-1139	TL PLUS Wire Tensioner With Tip	2
11103	Screw Guide, length 100mm	3
1100201	Drill Bit Ø 4.8mm length 240mm	1
11004	Trocar	1
30017	Allen Wrench 5mm	1
1100101	Drill Bit Ø 4.8mm length 180mm	1
11105	Drill guide Ø 4.8mm length 80mm	1

CONNECTION ELEMENTS

Part #	Description
99-885000M	TLEVO Nut With Washer Pack of 5 Sterile
99-885001M	TLEVO Wire Fixation Bolt Pack of 4 Sterile
99-885003M	TLEVO Bolt Pack Of 4 L16.5mm Sterile
99-885007M	TLEVO Half Pin Fixation Bolt Pack of 4 Sterile
99-885002M	TLEVO 8Mm Half Pin Fixation Bolt Pack of 4 Sterile
99-885008M	TLEVO Speed Nut Pack of 2 Sterile
99-885009M	TLEVO Speed Bolt Pack of 2 Sterile
99-885004	TLEVO 2 Holes Post Sterile
99-885005	TLEVO 3 Holes Post Sterile
99-885006	TLEVO 4 Holes Post Sterile

DIAPHYSEAL FIXATOR

Part #	Description	Qty
90001	Procallus Long	1
90000	Procallus Standard	1
90028	Procallus Short	1
80022	Procallus Fixator Hybrid Connection	1
90038	Supplementary Screw Holder Clamp	4
80042	Post Length 50mm	2
81043	Supplementary Screw Holder Bar Radiolucent 300mm	2
10017	Allen Wrench 6mm	1
10025	Torque Wrench 6mm	1

BONE SCREWS (Sterile)

Part #	Description
99-911530*	XCaliber Bone Screw L150/30mm Thread Ø 6.0-5.6mm
99-911540*	XCaliber Bone Screw L150/40mm Thread Ø 6.0-5.6mm
99-911550*	XCaliber Bone Screw L150/50mm Thread Ø 6.0-5.6mm

* HA half pins also available

KIRSCHNER WIRES (Sterile)

Part #	Description
99-54-1215	TL, Wire, W/Stopper, 1.8mm x 400mm
99-54-1216	TL, Wire, Bayonet, 1.8mm x 400mm

Alternative to the connection elements, additional components, bone screws and Kirschner Wire Tables, the TL-EVO connection element set code 99-88020 can be used.

99-88020 TL-EVO Connection Element K Wires and Cylindrical Pins Set Sterile*
Consisting of:

Part #	Description	Qty
99-941640	XCALIBER CYLINDRICAL SCREW SHAFT D6MM THREAD 6MM L 180/40 QC (941640)	3
99-885002	TRUELOK EVO 8MM HALF PIN FIXATION BOLT	3
99-54-1216	TL WIRE BAYONET D1.8MM L400MM	3
99-885001	TRUELOK EVO WIRE FIXATION BOLT	6
99-885003	TRUELOK EVO BOLT L16.5MM	3
99-885004	TRUELOK EVO 2 HOLES POST	2
99-885005	TRUELOK EVO 3 HOLES POST	2
99-885006	TRUELOK EVO 4 HOLES POST	2
99-885000	TRUELOK EVO NUT WITH WASHER	12
52-1020	TL HEX DRIVER 1/8"	1
54-1154	TL WRENCH COMBO 10MM	1
54-2226	TL 90 DEGREE TUBULAR WRENCH	1
93162	T-WRENCH HEXAGON 5-5 QC	1
11137	SCREW GUIDE L 80MM	1
11105	DRILL GUIDE D4.8MM L80MM	1
1-1100201	DRILL BIT D4.8MM L240MM TIN COATED - QC	1

The TL PLUS Wire Tensioner (54-1139) has to be ordered separately

* Products may not be available in all markets because product availability is subject to the regulatory and/or medical practices in individual markets. Please contact your Orthofix representative if you have questions about the availability of Orthofix products in your area.

The TrueLok™ EVO ProCallus™ Hybrid System is compatible with Standard bone screws, Titanium bone screws, Standard coated bone screws, Self-drilling coated bone screws, self-drilling bone screws, Transfixing Pins and Implantable wires.

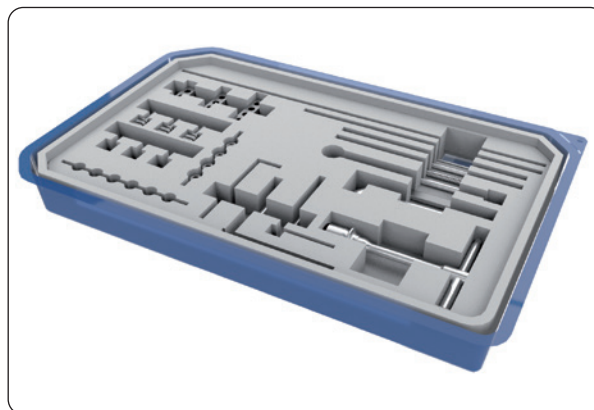

XCALIBER™ HYBRID SYSTEM SURGICAL PROCEDURE TL-EVO RING APPLICATION

SAFE CORRIDORS

In figures A, B and C safe corridors for the insertion of the fixation elements are represented.



PRECAUTION: Screws and wires must be inserted with full knowledge of the safe corridors to avoid damage to the anatomical structures.

Distal Femur

Wire and screw fixation in the distal femur is challenging due to the important periarticular structures present. Furthermore, narrow wire crossing angles produce instability in the sagittal plane. Correct wire and screw insertion is therefore crucial.

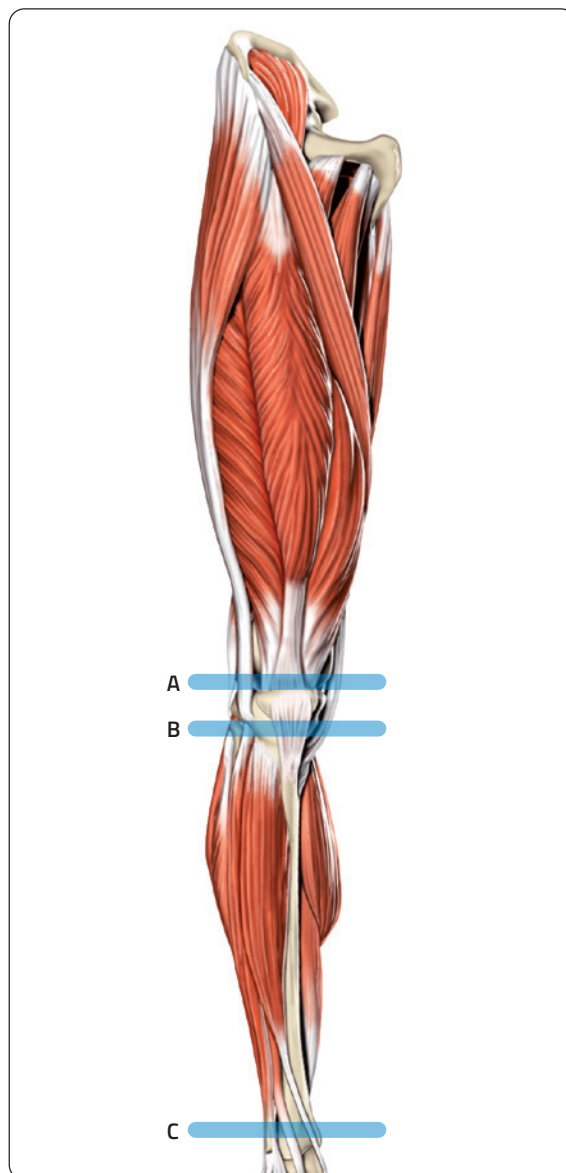

Firstly insert a wire from lateral to medial. Then insert two screws: one screw from postero-lateral to anteromedial, anterior to the Biceps Femoris Tendon, and one screw from postero-medial to anterolateral, anterior to the Sartorius. Wire and screws should be inserted with the knee flexed.

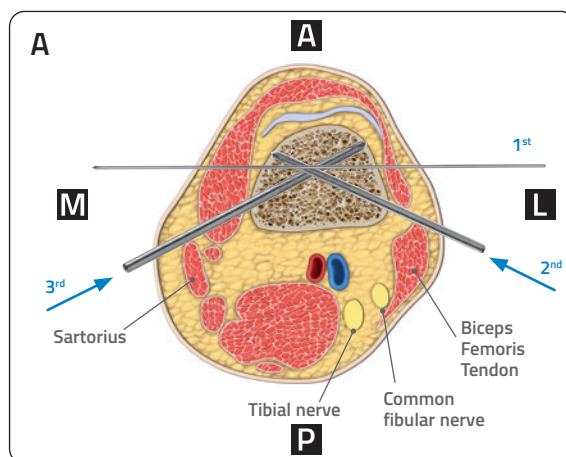

Proximal tibia

When inserting wires in the proximal tibia, the head of the fibula is an important landmark, since the Common Fibular Nerve passes posterior to it. Care should be taken to avoid damage to this nerve and to the joint capsule. The first wire should pass from postero-lateral to antero-medial between the patellar tendon and pes anserinus. The crossing wire should be inserted at the widest angle neurovascular structures will permit from postero-medial to antero-lateral. The third wire should be inserted from lateral to medial.

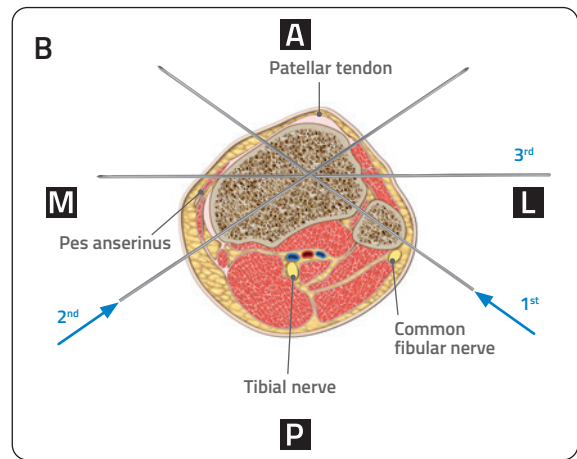

Distal tibia

The most distal wire should be inserted first, approximately 1cm proximal to the articular surface of the tibia so that the more proximal wire remains close to, or immediately above, the level of the inferior tibio-fibular joint. The first wire passes trans-fibular from postero-lateral to antero-medial and should be medial to the Tibialis Anterior Muscle. The crossing wire should be inserted from postero-medial to antero-lateral, exiting lateral to the tendon of Extensor Digitorum Longus at the widest angle neurovascular structures will permit. The third wire should be inserted from lateral to medial.

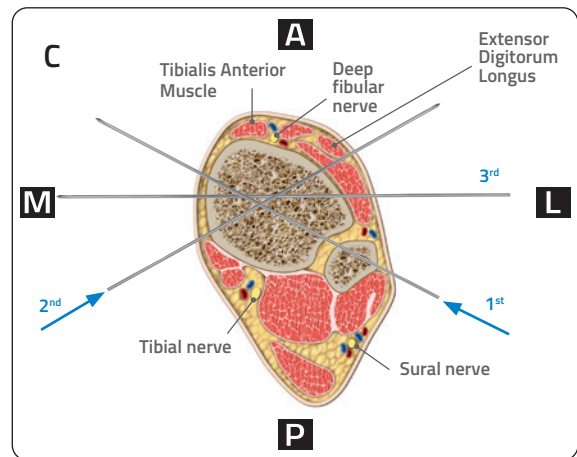

Displaced Articular Fractures

Where there is articular involvement, the frame may be applied after limited percutaneous reduction of the major articular fragments using either interfragmentary screws or the Orthofix Fragment Fixation System Implants. In this situation, sufficient room (10-20mm) should be left between the articular surface and the internal fixation to place the wires.

SURGICAL PROCEDURE FOR TIBIAL PLATEAU FRACTURE

Part #	Description
886663	TrueLok EVO Ring and Strut Templates

Use the provided templates to choose the appropriate ring sizes according to limb dimension.

Wire Insertion

Part #	Description
54-1154	TL Wrench Combo 10mm
54-2226	TL 90 degree Tubular Wrench



PRECAUTION: Screws and wires must be inserted with full knowledge of the safe corridors to avoid damage to the anatomical structures.

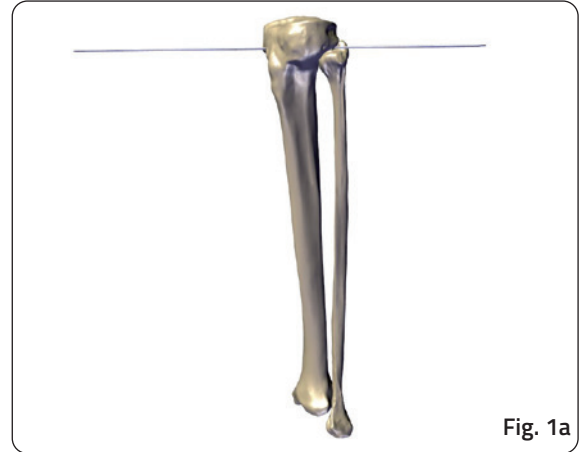

Fig. 1a

Refer to the safe corridors (page 8) for wire insertion. The sequence of wire insertion will vary depending on the fracture or specific nature of the disorder and the surgeon's preference.

For optimal stability three proximal tibial wires should be applied. The first wire can be inserted free-hand from postero-lateral to antero-medial. It is possible to insert the wire through the head of the fibula or just anteriorly (Fig. 1a).

Optional: If needed, perform reduction with an olive wire. Compress the fracture line by pulling the wire gently with the tensioner under Image Intensifier. Stop when the fracture gap has closed.

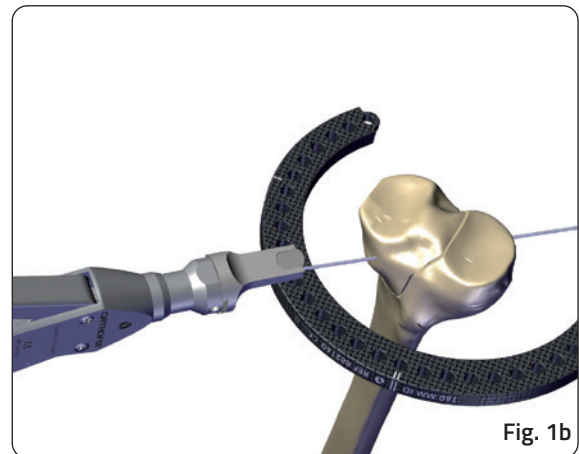

Fig. 1b

Attach the wire to the ring using a wire fixation bolt and nut at each end. Check that the limb is centrally placed within the ring and keep the ring perpendicular to the tibial anatomic axis (Fig. 2).



WARNING: Use only "TL-EVO wire fixation bolts" and "TL-EVO nuts with washer" when using TL-EVO rings in order to avoid ring surface damage and subsequent loss of fixation.



Fig. 2

Insert the second wire from postero-medial to anterolateral (**Fig. 3**).

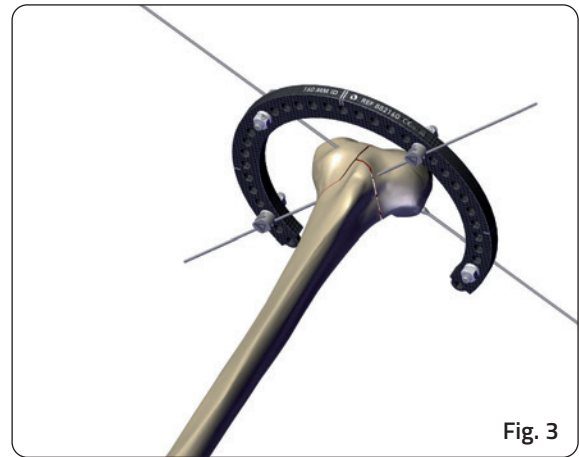

Fig. 3

Insert the third wire from lateral to medial (**Fig. 4**).



PRECAUTION: It is recommended to position at least one wire on the opposite side of the ring with respect to the other two wires.



PRECAUTION: If necessary, to avoid bending the wire, the space between the ring and the wire can be filled using a post, or remove the wire and reinsert in a different position.

Complete the 5/8 ring to a full ring if necessary prior to tensioning any wires.



PRECAUTION: During and after insertion of the implants, ensure their correct positioning under image intensification.

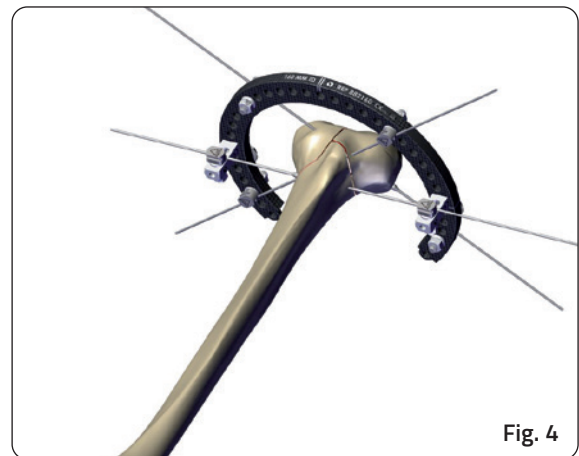

Fig. 4

Wire Tensioning

Part #	Description
54-1139	WIRE TENSIONER
54-1154	TL WRENCH COMBO 10MM
54-2226	TL 90 DEGREE TUBULAR WRENCH

Tension the first two wires simultaneously (**Fig. 5**). Tighten the nut with the 10mm wrench, locking the wire fixation bolt present at the opposite side from the one where tensioner will be applied. Ensure the tensioner head captures the wire fixation bolt appropriately. Based on the characteristics of the patient and the fracture, tension the wires up to 130Kg; tighten the nut on the wire fixation bolt securely prior to releasing the tensioner. Tension the third wire in the same way. In case a wire with olive is used, tensioning must be performed from the side opposite the olive.



PRECAUTION: To avoid causing injury, the ends of wires should be protected with special covers or bent at the ends as soon as they are tensioned.

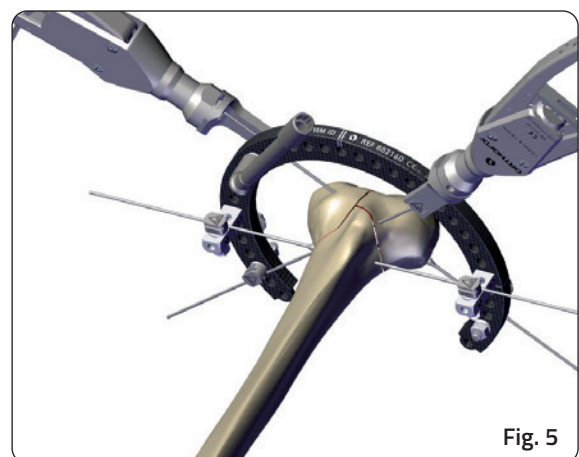

Fig. 5

PROCALLUS™ APPLICATION

The ProCallus fixator comes in three sizes: short, standard and long. Check that the appropriate size is assembled correctly before attaching the fixator to the TL-EVO ring.

PROCALLUS FIXATOR HYBRID CONNECTION ASSEMBLY

Insert one cam into the body of the device with the dot facing the adjacent clamp site.

The two Allen Wrench fitting points must be positioned on the same side.



Insert the bush with its groove facing the cam.

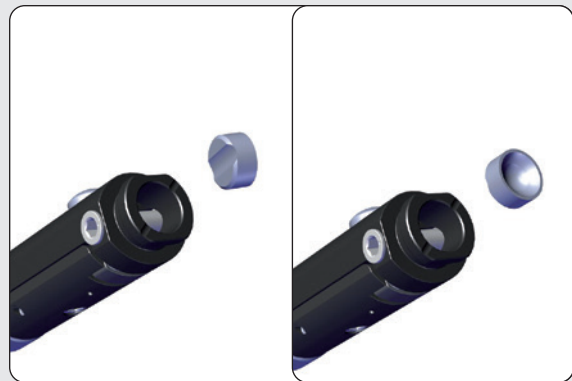

Rotate the bush with the finger to ensure that the cam is seated in its groove.

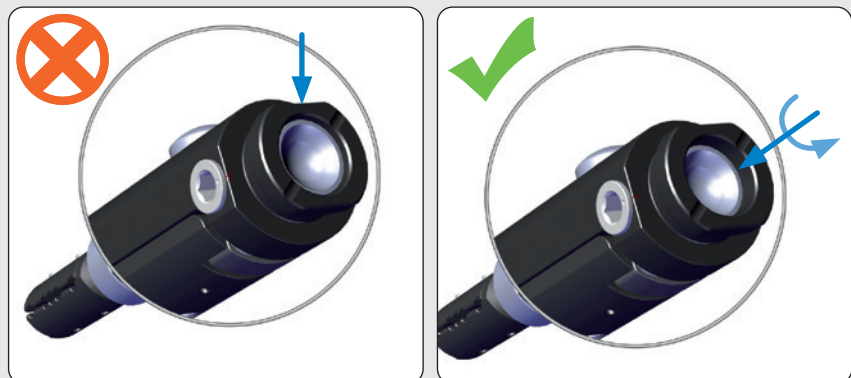

Turn the cam so that its dot is facing the open end of the fixator. Now hold the cam in place with the thumb.

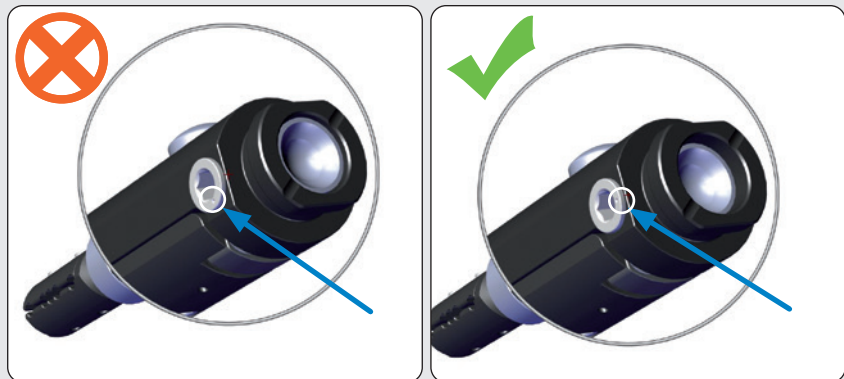

Take up the ProCallus Fixator Hybrid Connection and line up body and clamp (note squared sides). The dot on the cam should point towards the clamp. Insert body into clamp (bayonet-type locking).

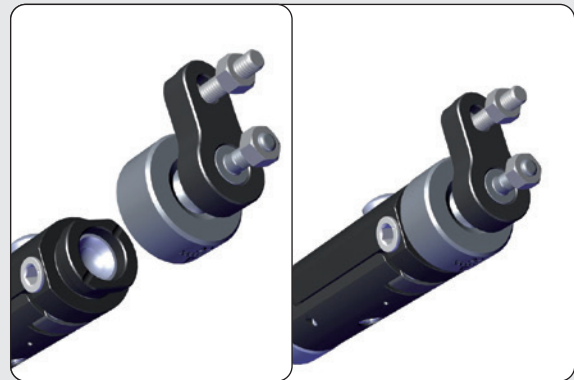

Using slight pressure, rotate the collar 90° to line up its arrow with the dot on the cam. The ring then closes with a click.

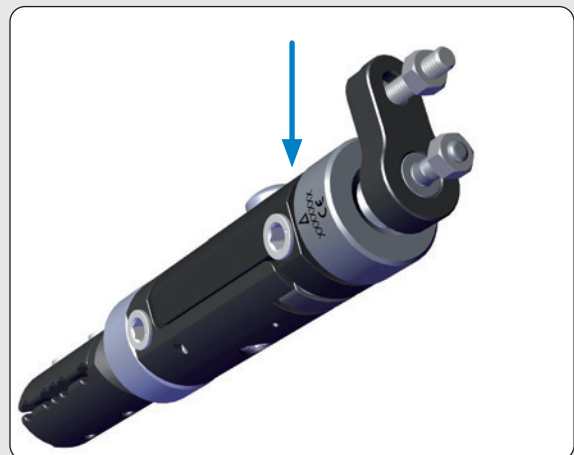

Part #	Description
54-1154	TL Wrench Combo 10mm
10017	Allen Wrench 6mm

Position the fixator parallel to the long axis of the bone and attach it to the ring. Lock the two nuts with washer using the 10mm Wrench (**Fig. 6**). Ensure all cams and locking nuts are accessible for tightening. Check that the fixator body is neither fully closed nor fully open.



WARNING: Use only “TL-EVO wire fixation bolts” and “TL-EVO nuts with washer” when using TL-EVO rings in order to avoid ring surface damaging and subsequent loss of fixation.

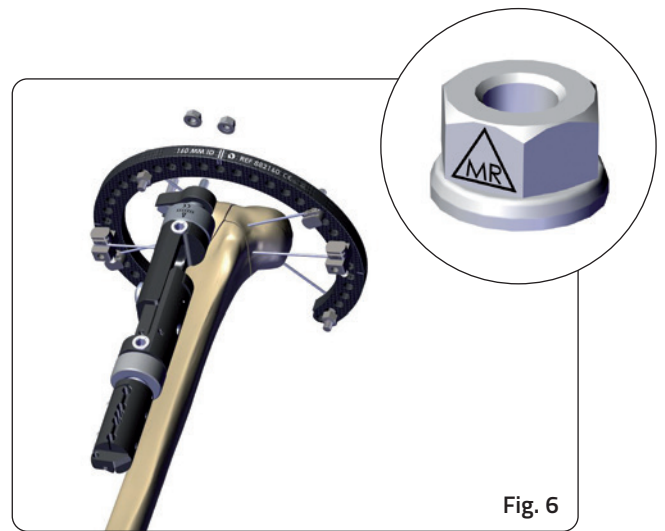

Fig. 6

Lightly tighten the two ball-joints with a 6mm Allen Wrench to hold the fixator body in position (**Fig. 7**).



Fig. 7

DIAPHYSEAL SCREW INSERTION

Part #	Description
11103	Screw Guide, length 100mm
11105	Drill Guide, D4.8mm length 80mm
1100201	Drill Bit, D4.8mm length 240mm
91150	Universal T-Wrench
10017	Allen Wrench 6mm
54-1154	TL Wrench Combo 10mm
11004	Trocar
10025	Torque Wrench 6mm

The clamp acts as its own template for the insertion of the bicortical screws. Insert the number of screws required to ensure good stability. For adults, 3 screws are recommended. When only two screws are to be inserted, it is recommended to use clamp seats 1 and 5.

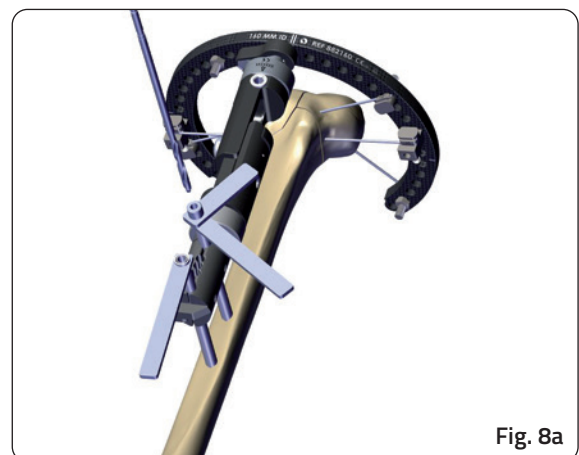

Fig. 8a

When inserting three screws use seats 1, 3 and 5. Open the clamp cover to insert the screw guides and close the cover firmly to keep them parallel. Check that the fixator body is parallel to the bone axis, and the screw guides are perpendicular to the bone axis. Using a 4.8mm drill guide and drill bit, drill both the first and second cortices (**Fig. 8a**). Remove the drill guide, wash away bone chips with saline, and manually insert the bone screw with the T-Wrench (**Fig. 8b**). Repeat this procedure to insert all the screws. After all the screws have been inserted, remove the screw guides before finally tightening the clamp cover. If needed, use a trocar to locate the midline by palpation. Keep the screw guide in contact with the cortex by gentle pressure, withdraw the trocar and tap the screw guide lightly to anchor its distal end.



WARNING: Axial displacement may occur if the body of the fixator is not in line with and parallel to the bone.



WARNING: Medial or lateral translation may occur if the body of the fixator is not placed parallel to the diaphysis.



PRECAUTION: Diaphyseal bone screws should always be inserted perpendicular to and in the centre of the bone axis to avoid weakening it.

With both cams loosened, final reduction is now carried out. The cams are locked firmly with the 6mm Allen Wrench by turning them CLOCKWISE. The micromovement locking nut and central body locking nut are also locked with the 6mm Allen Wrench. Final locking of the ProCallus ball-joints is performed using the Torque Wrench, which must be turned IN A CLOCKWISE DIRECTION ONLY. A click indicates the correct torque (**Fig. 9a**).

Use the Torque Wrench for final locking of ProCallus ball-joints only.



WARNING: Any attempt to unlock the cam or any screw using the torque wrench will damage its gearing.

BARS APPLICATION

Part #	Description
54-1154	TL Wrench Combo 10mm
10017	Allen Wrench 6mm

Two reinforcement bars should be added for stability, connecting the diaphyseal screws to the ring. Insert two 50mm posts into the ring and connect the bars by using the supplementary screw holder clamps. Connect the bars to the bone screw ends using two supplementary screw holder clamps (**Fig. 9b**).

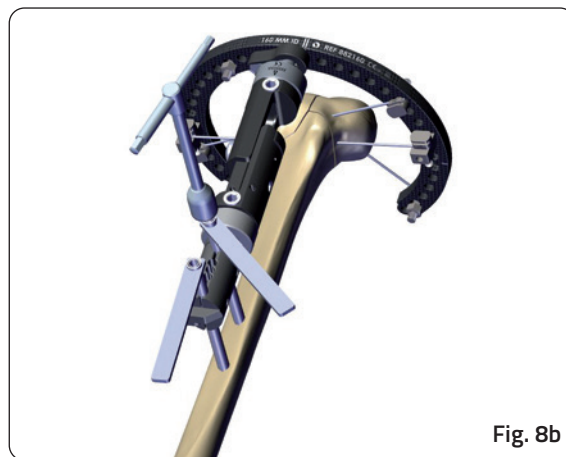

Fig. 8b

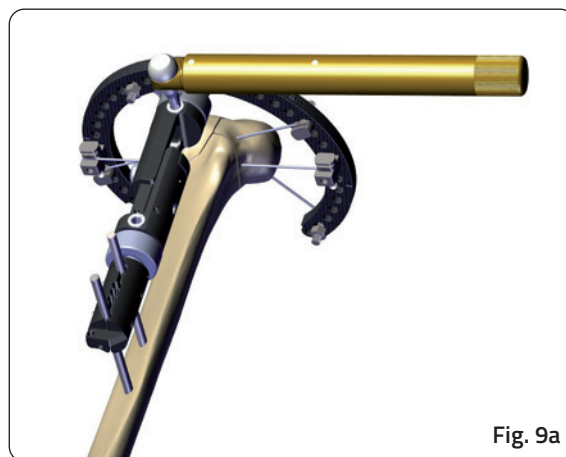

Fig. 9a



Fig. 9b

POST OPERATIVE MANAGEMENT

Depending on fracture-type, and reduction as well as patient characteristics, active and passive mobilization may be commenced shortly after surgery. Patient is allowed initial toe-touch weight bearing. Progressive weight bearing and physiotherapy should be established according to the surgeon's evaluation of the fracture stability and of the information derived from radiological assessment. During the post-operative period, the elasticity of the wires will allow sufficient micromovement at the fracture site to stimulate callus formation. Removal of the reinforcement bars is recommended when callus is first seen on X-ray to increase load sharing at the fracture site.



PRECAUTION: Dynamization by loosening the micromovement locking nut and/or the central body locking nut of the monolateral fixator is not recommended in hybrid frames.

FRAME REMOVAL

Part #	Description
91150	Universal T-Wrench
54-1154	TL Wrench Combo 10mm
54-2226	TL 90 degree Tubular Wrench
30017	Allen Wrench 5mm

Untighten all the wire fixation bolts using the appropriate wrenches (54-1154 or 54-2226). Remove the wires with the power drill. Untighten the Procallus fixator locking nut, central body locking nut and ball-joints using the 6mm Allen Wrench. Disassemble the frame removing the entire frame from the limb. Remove all bone screws manually with the Universal T-Wrench (91150) or with a power drill.

MRI SAFETY INFORMATION

The TL-EVO Procallus Hybrid System has not been evaluated for safety and compatibility in the MR environment. It has not been tested for heating, migration, or image artifact in the MR environment. The safety of the TL-EVO Procallus Hybrid System in the MR environment is unknown. Scanning a patient who has this device may result in patient injury.

Please refer to the "Instructions for Use" supplied with the product for specific information on indications for use, contraindications, warnings, precautions, possible adverse events, MRI (Magnetic Resonance Imaging) safety information and sterilization.

Electronic Instructions for use available at the website <http://ifu.orthofix.it>

Electronic Instructions for use - Minimum requirements for consultation:

- Internet connection (56 Kbit/s)
- Device capable to visualize PDF (ISO/IEC 32000-1) files
- Disk space: 50 Mbytes

Free paper copy can be requested from customer service (delivery within 7 days):

tel: +39 045 6719301, fax: +39 045 6719370

e-mail: customerservice@orthofix.it

Caution: Federal law (USA) restricts this device to sale by or on the order of a physician. Proper surgical procedure is the responsibility of the medical professional. Operative techniques are furnished as an informative guideline. Each surgeon must evaluate the appropriateness of a technique based on his or her personal medical credentials and experience.



Manufactured by:
ORTHOFIX Srl
Via Delle Nazioni 9, 37012 Bussolengo
(Verona), Italy
Tel: +39 045 6719000
Fax: +39 045 6719380
www.orthofix.com

Rx Only

CE₀₁₂₃

Distributed by:

