

THE ELBOW FIXATOR

PART A: ACUTE TRAUMA

13

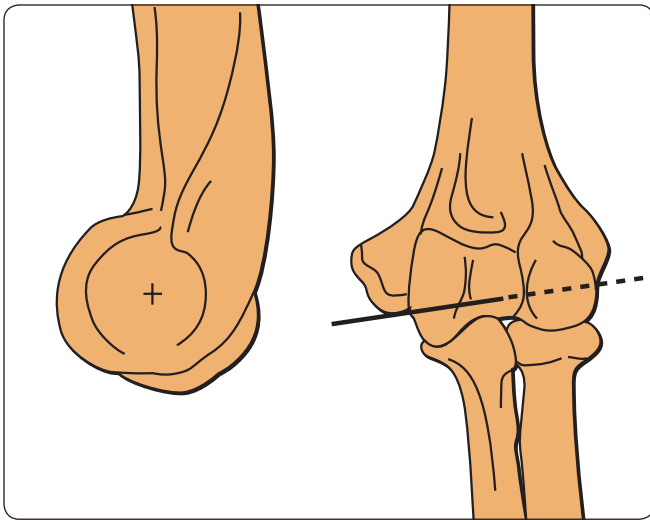

Please kindly refer to the product IFU PQEFS, to the Orthofix implantable devices and related instrument IFU PQSCR, and to the reusable medical devices IFU PQRMD that contain instructions for use of the product.

Insert a 2mm Kirschner wire to a depth of 2-3 cm, through the centre of rotation of the elbow joint under image intensification. Check its position in both planes.

In comminuted fractures, it is sufficient to engage the first cortex only.

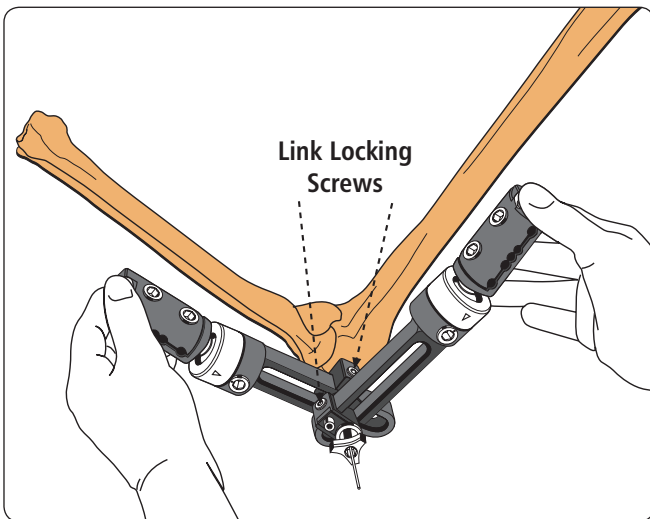

Slide the fixator over the 2mm Kirschner wire. Adjust the position of the links so that sufficient space is available for subsequent correction.

The link locking screws are provisionally tightened at this point.

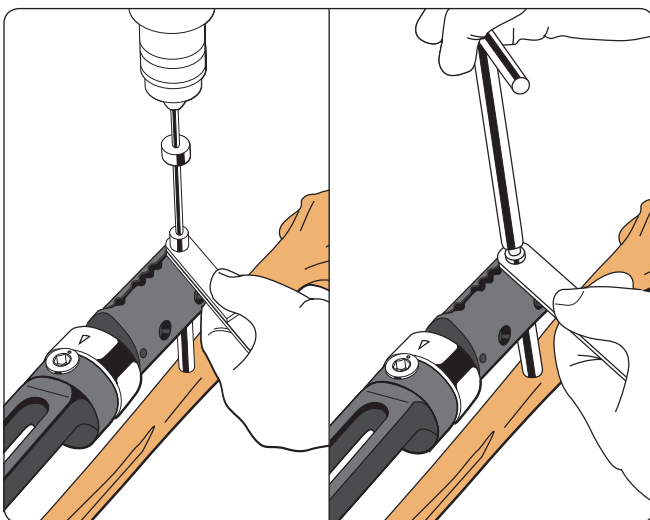

HUMERAL SCREW INSERTION

Expose the lateral aspect of the humerus by blunt dissection in order to avoid damage to the radial nerve. Insert the most proximal screw first, at the distal insertion of the deltoid muscle. After pre-drilling with a 4.8mm drill bit, insert a 100/30 or 110/30 6-5mm diameter screw.

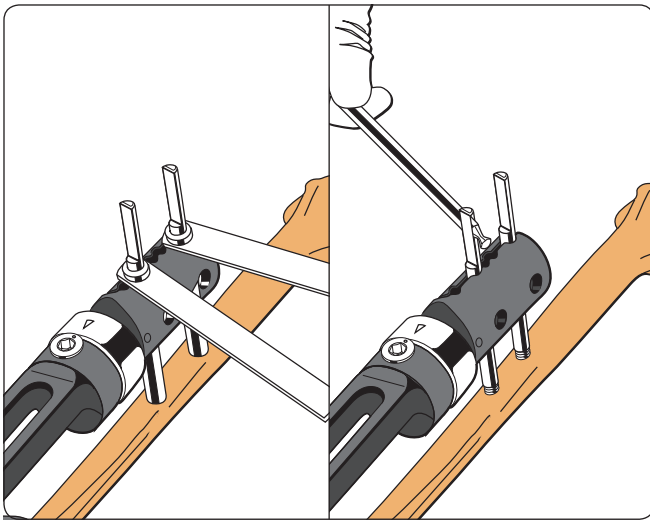

Insert the second humeral screw in the same manner, in the 4th screw seat of the clamp.

In small humeri, where the diameter of the bone is less than 20mm, use screws with a smaller thread diameter, 4.5-3.5mm.

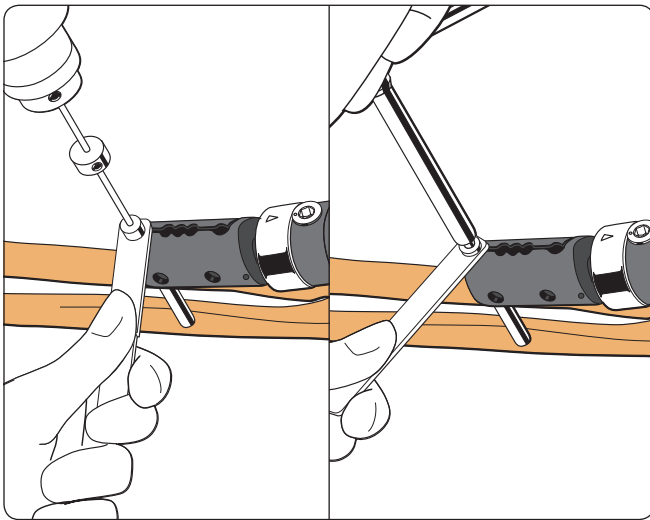

ULNAR SCREW INSERTION

With the forearm in the neutral position, apply the ulnar screws from the dorsal side, placing them as centrally as possible to avoid weakening the bone. After pre-drilling with a 3.2mm drill bit, insert the most distal screw first. Always use a 120/20 or 100/20 4.5-3.5mm diameter screw. Bicortical purchase is required.

Open exposure is advisable.

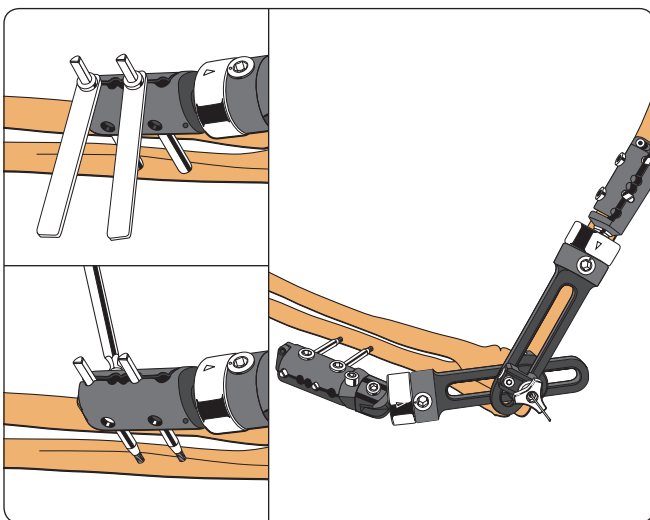

Insert the second ulnar screw in the same manner, in the 4th screw seat of the clamp.

An Extended Range Clamp may be used if it is not possible to insert both screws exactly in the centre of the bone.

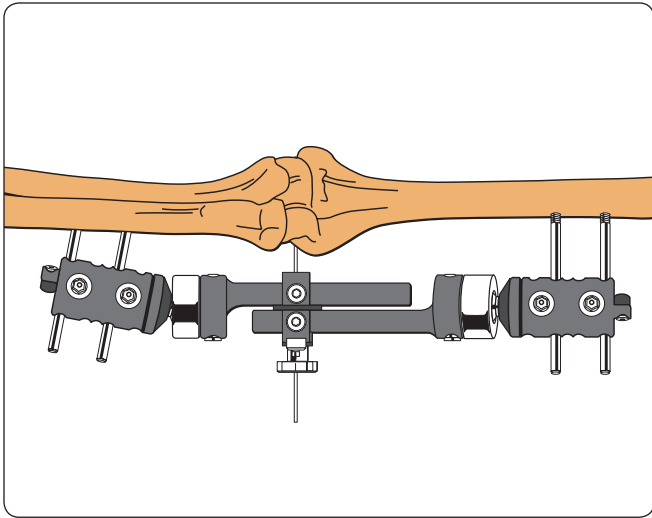

Check fixator alignment in the AP view.

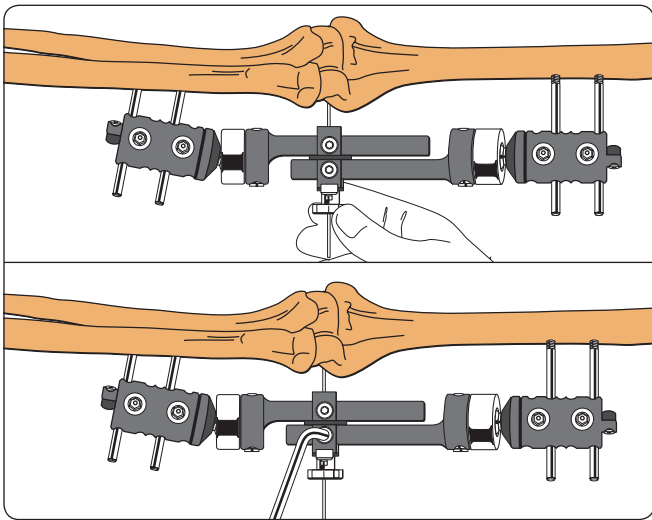

Lock the triangular knob and then each of the link locking screws.

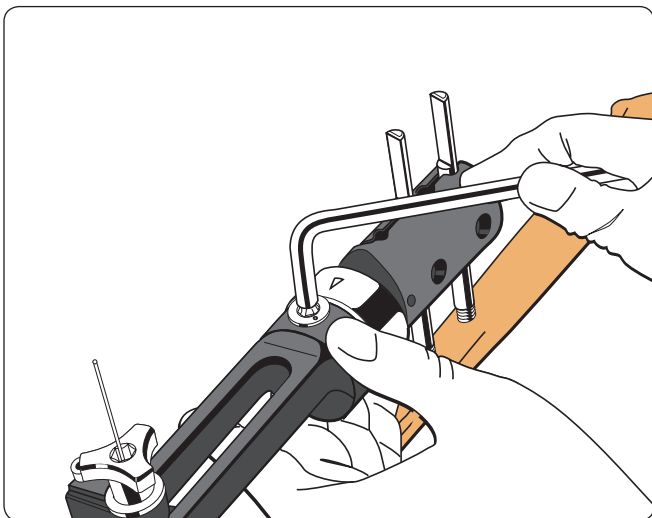

Finally, tighten the ball-joints with a 6mm Allen Wrench.

Follow this sequence strictly otherwise the links may bend or jam.

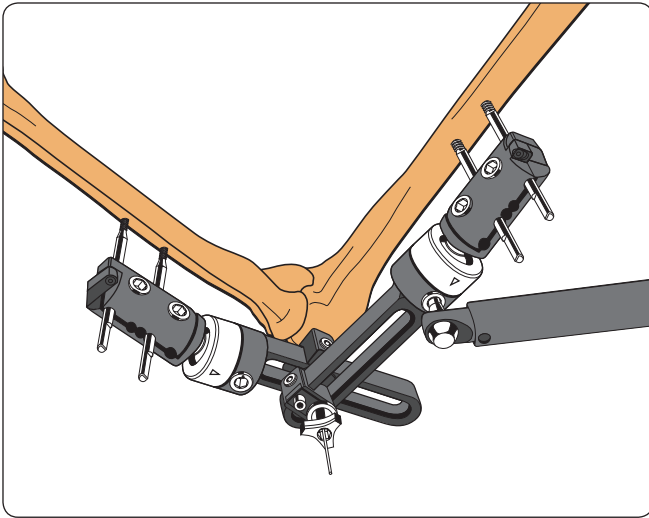

With the triangular knob loosened, flex and extend the elbow under image intensification to confirm correct fixator alignment and symmetrical joint opening. Finally, lock the ball-joints with the torque wrench.

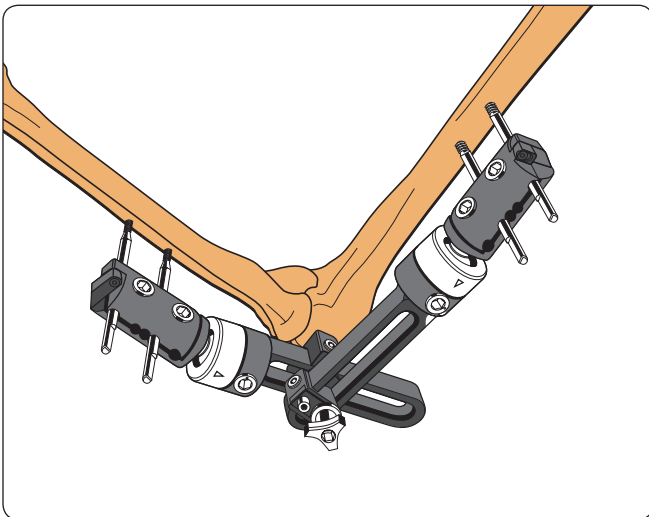

Using the triangular knob of the central connecting unit, lock the fixator at an appropriate angle (70° of flexion from full extension is recommended). Remove the 2mm Kirschner wire.

Electronic Instructions for use available at the website
<http://ifu.orthofix.it>

Electronic Instructions for use - Minimum requirements for consultation:

- Internet connection (56 Kbit/s)
- Device capable to visualize PDF (ISO/IEC 32000-1) files
- Disk space: 50 MBytes

Free paper copy can be requested from customer service (delivery within 7 days):
tel +39 045 6719301, fax +39 045 6719370,
e-mail: customerservice@orthofix.it

Distributed by:



Manufactured by:
ORTHOFIX Srl
Via Delle Nazioni 9, 37012 Bussolengo (Verona), Italy
Telephone +39 045 6719000, Fax +39 045 6719380



Caution: Federal law (USA) restricts this device to sale by or on the order of a physician. Proper surgical procedure is the responsibility of the medical professional. Operative techniques are furnished as an informative guideline. Each surgeon must evaluate the appropriateness of a technique based on his or her personal medical credentials and experience. Please refer to the "Instructions for Use" supplied with the product for specific information on indications for use, contraindications, warnings, precautions, adverse reactions and sterilization.