

OPERATIVE TECHNIQUE

Fitbone™

Intramedullary Lengthening System

**Fitbone Transport
and Lengthening System
Antegrade Femur
Application**



Fitbone™

Intramedullary Lengthening System

Table of Contents

1	Surgery planning - antegrade femur
1	Fitbone Transport and Lengthening System Nail types
2	Surgery
4	Insertion of half pins (selfdrilling XCaliber cylindrical screw shaft) for torsion control
5	Reaming of the medullary cavity
5	Approach and initial reaming with Rigid Reamers
9	Initial reaming
10	Reaming of the medullary cavity with Rigid Reamers
12	Extracting the working tube
13	Approach and initial reaming with Flexible Reamers
14	Osteotomy
14	Dummy TAA/Trial nail TN/TLN and Jig assembly
16	Insertion of the Dummy TAA/Trial Nail TN/TLN
17	Potential problems and solutions
18	Blocking Screws insertion
19	Removal of the recharging screw
20	Insertion of the Fitbone TN/TLN
25	Final intraoperative test
27	Docking site compression and healing
27	Lengthening (optional) with the Fitbone TN/TLN
30	Fitbone Bone Transport and Lengthening System – removal opt – antegrade femur

The surgical technique shown is for illustrative purposes only. The technique(s) actually employed in each case will always depend upon the medical judgment of the surgeon exercised before and during surgery as to the best mode of treatment for each patient. Please kindly refer to the product IFU PQFBT and to the reusable medical devices IFU PQRMD that contain instructions for use of the product.

SURGERY PLANNING - ANTEGRADE FEMUR

These following points are considered during the pre-operative plan.

- Deformity correction (if required)
- Defect size and location
- Medullary canal diameter
- Optimal nail length
- Location of bone transport screw (maintain at least 10mm, or more in case of poor bone quality, between the transport screw and resection site/osteotomy site).
- Location of blocking screws (maintain at least 10mm between the blocking screw and resection site/osteotomy site).
- Location of osteotomy (maintain at least 10mm between screw (locking or blocking) and osteotomy).
- Required additional lengthening (for TLN).
- Required nail "rewind and go" (see page 28) and new location of the bone transport screw by recharging the nail.



Fig. 1 Fitbone Transport and Lengthening System - Femoral nail

TN and TLN trial nails are optionally available and should be ordered separately.

Please refer to the next point for all available Fitbone TN and TLN lengths diameters and bone transport / lengthening strokes available. .

FITBONE TRANSPORT AND LENGTHENING SYSTEM NAIL TYPES

Fitbone Transport Nails (Fitbone TN)

Fitbone TN Femur



Fitbone Transport and Lengthening Nails (Fitbone TLN)

Fitbone TLN Femur



SURGERY

Grid Plate

Part #	Description
60001464	FITBONE GRID PLATE

The GRID plate is recommended in Fitbone surgeries to ensure the correct limb alignment and deformity correction (if needed). The GRID plate is placed on the operating table underneath the cushion. To prevent damage to the GRID plate, it should rest flat over its entire surface.

Never place the GRID plate directly under the patient without padding.

The Grid plate has two double lines. The joint centres are placed over these double lines to ensure correct alignment.

Technical features of the grid

Material: Pertinax RI4 0000 (Hartpapier) PF CP 201 HP 2061
Dimensions: 37.6mm x 128.2mm.

50mm between longitudinal and transverse wires.

1mm between double wires (shown in bold in **Fig.2**).

The surgery is performed with the leg in full extension. (**Fig. 3**)

Patient positioning

The patient is placed supine on the operating table. The operated leg is draped to allow free movement. Ensure that the C-arm can produce an uninterrupted view of the hip, knee and ankle joint.

Ensure that the C-arm is perpendicular to the GRID plate and that the joints are viewed in the centre of the screen. This will minimize parallax errors.

Place the centre of the hip joint over the double radiopaque grid line while ensuring the patella faces forward.

Place the ankle joint over the double radiopaque grid line without changing limb rotation. (**Fig. 4**)

The center of the knee joint might not be on the double radiopaque grid line if a deformity is present. (**Fig. 5**)

Compare the alignment with preoperative planning. If the alignment matches that of the pre-operative plan, then proceed with surgery.

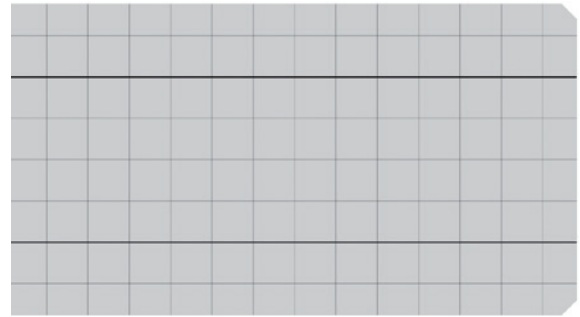

Fig. 2 GRID Plate

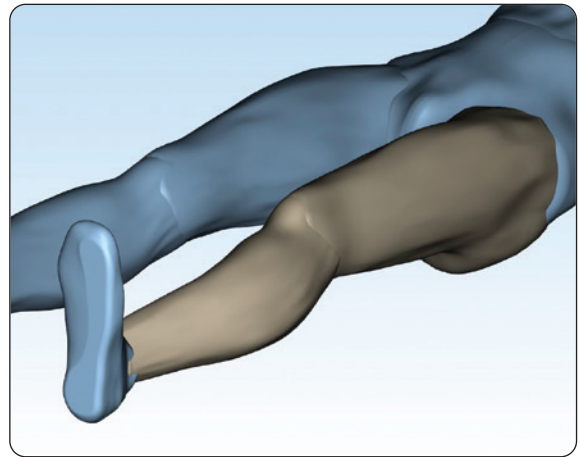

Fig. 3 Leg in full extension

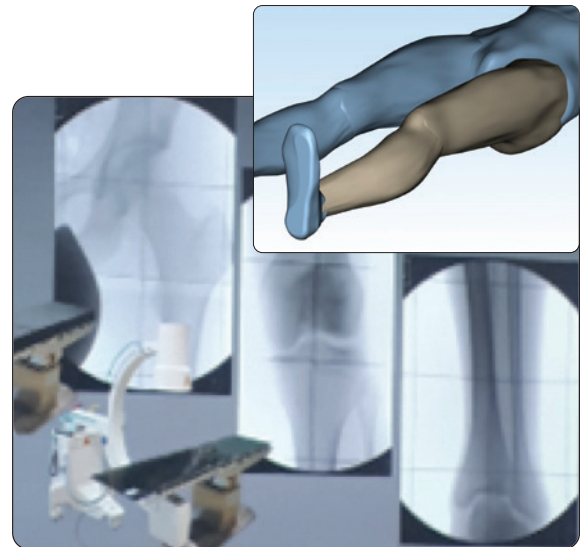

Fig.4 Patient positioning

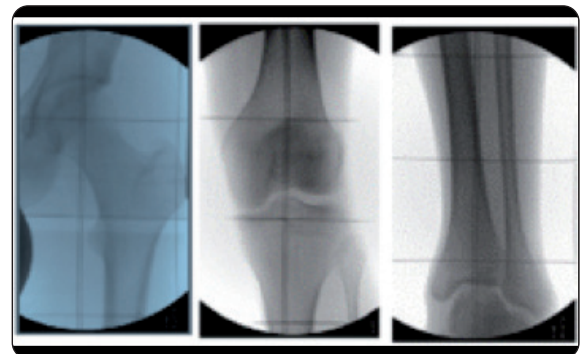

Fig. 5 Hip, knee and ankle joint position

Patient marking

Part #	Description
99-6000xxxx	FITBONE TRANSPORT TRIAL NAIL
99-6000xxxx	FITBONE TRANSPORT LENGTHENING TRIAL NAIL
60003516	FITBONE TRANSPORT SIZING GUIDE
60003517	FITBONE TLN SCREW OVERLAY
60003519	FITBONE FEMUR TN ANTEGRADE SCREW OVERLAY

Identify the hip joint and mark the level of the greater trochanter on the skin using a surgical skin marker. **(Fig. 6)**

The nail marking can be done by using the sizing guide or the correspondent Fitbone TN/TLN trial nail if available.

The sizing guide allows to check for diameter, total length, slot's length and position of the implant. **(Fig. 6a,6b and 6c)** When using the sizing guide place the corresponding TN/TLN screw overlay on the holes of the sizing guide at the correct length to check the position of the distal holes **(Fig. 6d)**.

In case of using a trial nail, this should be placed deep into the entry point.

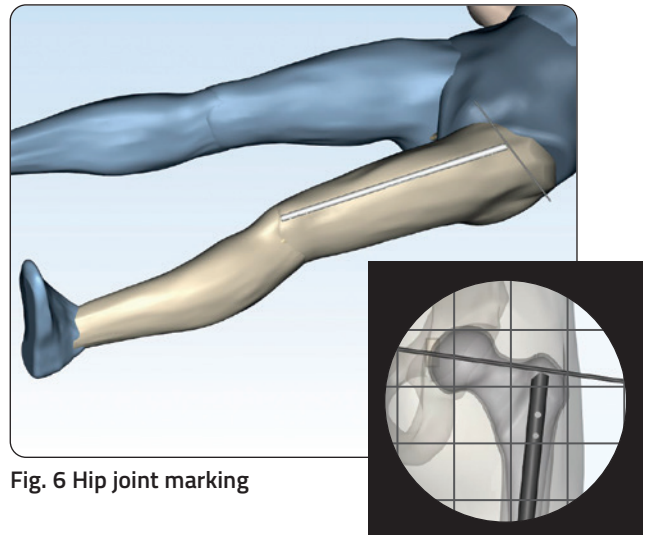

Fig. 6 Hip joint marking

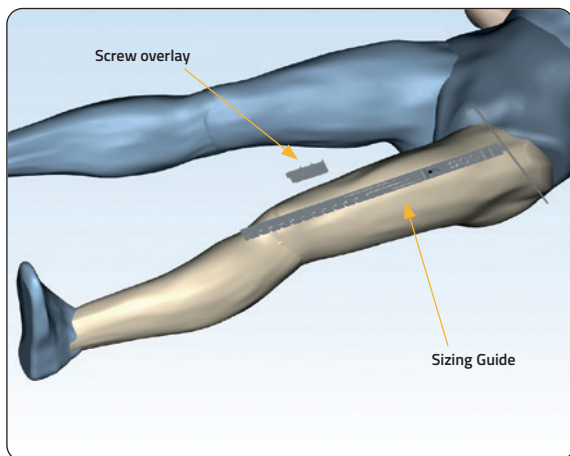

Fig.6a Sizing guide and Screw Overlay

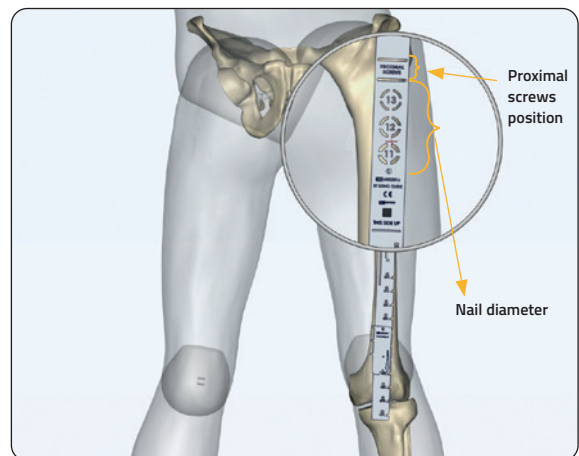

Fig. 6b Sizing guide proximal features

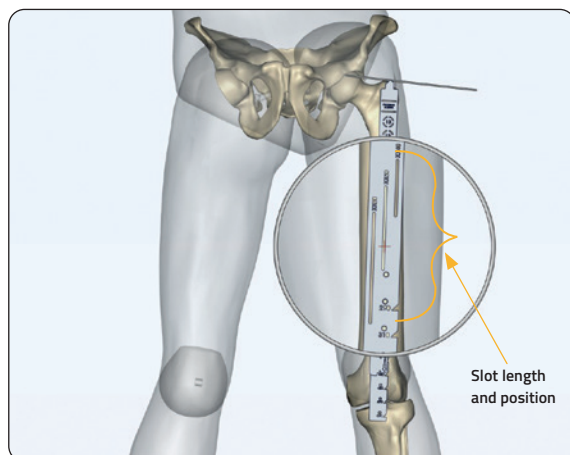

Fig. 6c Sizing guide slot length and position

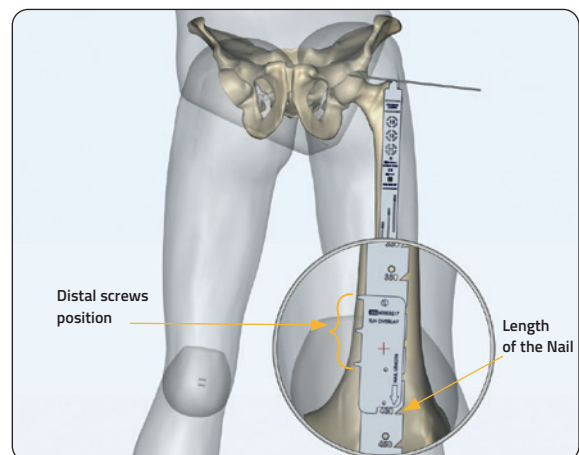

Fig. 6d Sizing guide distal features

Mark the osteotomy level according to the pre-operative planned change in diameter of the nail with a surgical skin marker and a surgical stapler. **(Fig. 7)**

Optionally, the nail contour and the screws position can also be marked according to the dimensions of the nail to be used.

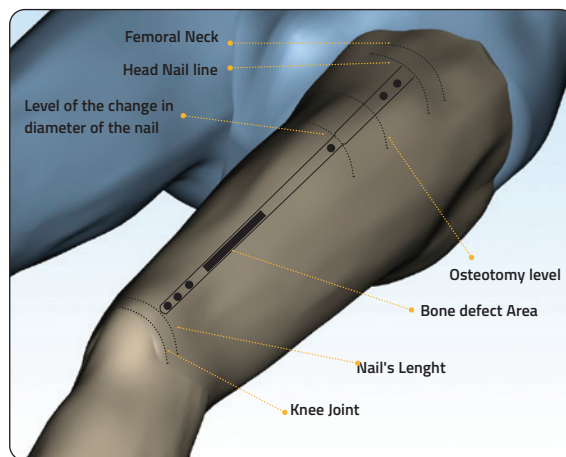

Fig. 7 Osteotomy and nail position marking

INSERTION OF HALF PINS (SELFDILLING XCALIBER CYLINDRICAL SCREW SHAFT) FOR TORSION CONTROL

Part #	Description
99-941550	SELFDILLING XCALIBER CYLINDRICAL SCREW SHAFT D6MM THREAD 5MM L180/50QC STERILE



PRECAUTION: Half-pins might be used to avoid unintentional axial and torsional deviations. These must be placed in such a way that they do not interfere with the insertion of the intramedullary nail into the medullary canal.

With the leg in full extension, insert two 4.5 or 5mm half-pins, to ensure correct torsional alignment.

Insert the first screw in the condylar region, posterior to the path of the nail, in the coronal plane, lateral to medial. **(Fig. 8)**

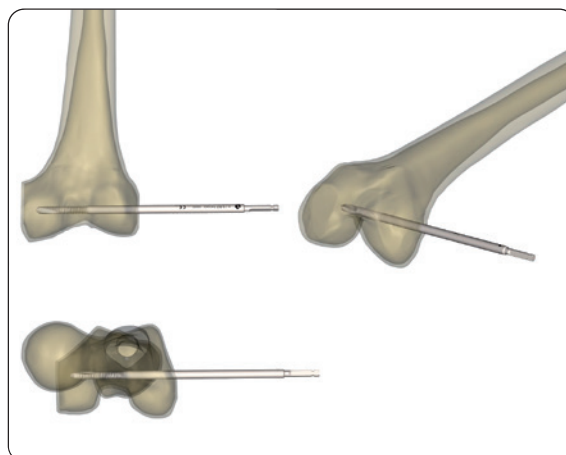

Fig. 8 Distal half-pin position

The second half-pin is inserted in the proximal femur, at the level of the lesser trochanter, posterior to the path of the nail, in the coronal plane, lateral to medial, parallel to the first half-pin if torsional correction is not needed. **(Fig. 9)**

The half-pins are placed as a visual cue to rotational alignment. At the end of the procedure, the half-pins should

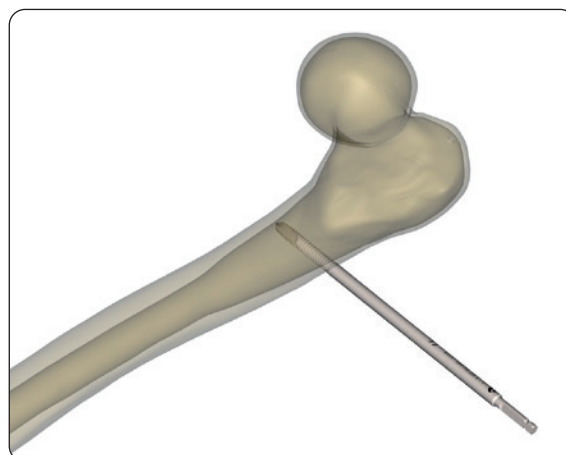

Fig. 9 Proximal half-pin position

be parallel to each other. (Fig. 10)

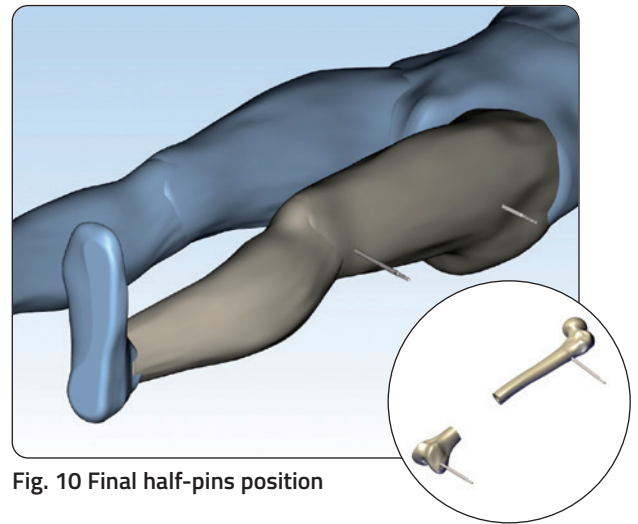

Fig. 10 Final half-pins position

Venting holes

Venting holes should be drilled at the osteotomy level to reduce pressure during reaming and allow bone debris to exit (Fig. 11).

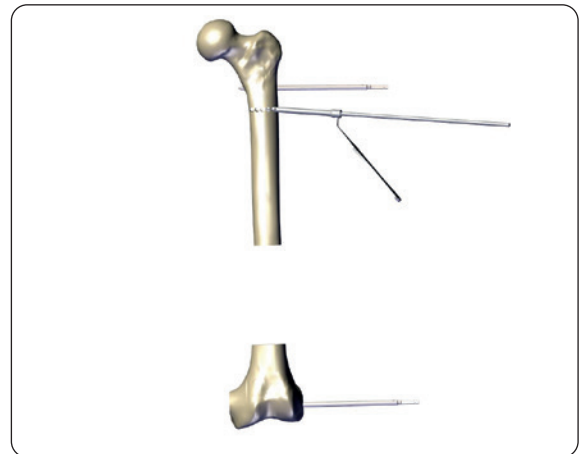

Fig. 11 Venting holes

REAMING OF THE MEDULLARY CAVITY

Fitbone Transport and Lengthening system instruments include rigid and flexible reamers, to be used as surgeon's discretion.

Next section will describe the reaming procedure with rigid reamers and the following section the reaming procedure with flexible reamers

APPROACH AND INITIAL REAMING WITH RIGID REAMERS

The use of 480mm long rigid reamers is limited for nails up to 350mm long.

Locate the greater trochanter by palpation or under x-rays. A longitudinal skin incision (approximately 4cm) is made proximal to the greater trochanter. (Fig. 12)

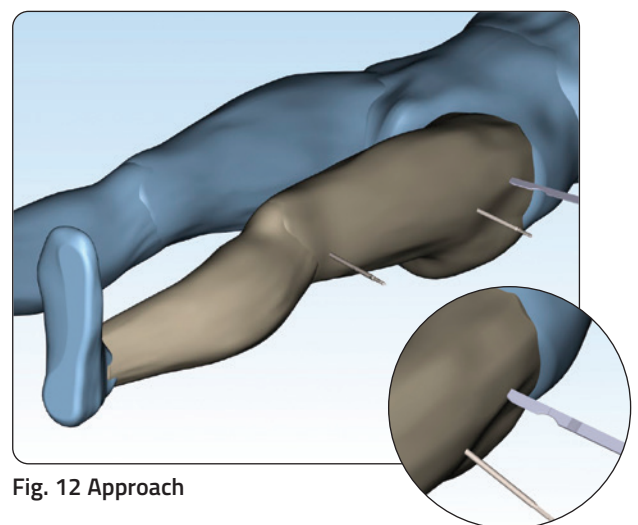

Fig. 12 Approach

Kirschner wire entry point

Part #	Description
60001039	FITBONE KIRSCHNER WIRE D3 L280

Insert the kirschner wire into the intramedullary canal, via the piriformis fossa using fluoroscopy in AP and lateral view. Direct the kirschner wire according to your pre-operative plan, directing the wire along the intended ultimate nail path (in case deformity correction is required) and parallel to the anterior cortex of the femur. (Fig. 13)

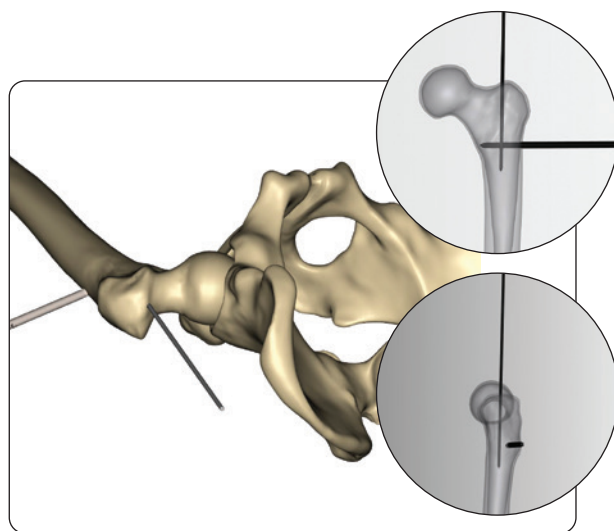

Fig. 13 Kirschner wire entry point

Cones and tubes

Part #	Description
60001014	Fitbone™ tube T14/13-M
60001015	Fitbone™ tube T13-12-M
60001016	Fitbone™ tube T12/11-M
60001017	Fitbone™ tube T12/10-M
60001018	Fitbone™ tube T12/09-M
60001054	Fitbone™ tube T14/13-L
60001055	Fitbone™ tube T13/12-L
60001020	Fitbone™ tube T12/11-L
60001021	Fitbone™ tube T12/10-L
60001022	Fitbone™ tube T12/09-L
60001054	Fitbone™ tube T14/13-XL
60001059	Fitbone™ tube T13/12-XL
60001024	Fitbone™ tube T12/11-XL
60001025	Fitbone™ tube T12/10-XL
60001026	Fitbone™ tube T12/09-XL
60001028	Fitbone™ cone C13
60001029	Fitbone™ cone C13+
60001030	Fitbone™ cone C13++
60001033	Fitbone™ tube-sinker TS13
60001036	Fitbone™ cone-sinker CS15-13
60001056	Fitbone™ tube T16/15-XL
60001057	Fitbone™ tube T15/14-XL
60001052	Fitbone™ tube T16/15-L
60001053	Fitbone™ tube T15/14-L
60001050	Fitbone™ tube T16/15-M
60001051	Fitbone™ tube T15/14-M
60001064	Fitbone™ tube-sinker TS15
60001060	Fitbone™ cone C15
60001061	Fitbone™ cone C15+
60001062	Fitbone™ cone C15++

Cones and tubes are recommended to perform minimally invasive and accurate reaming.

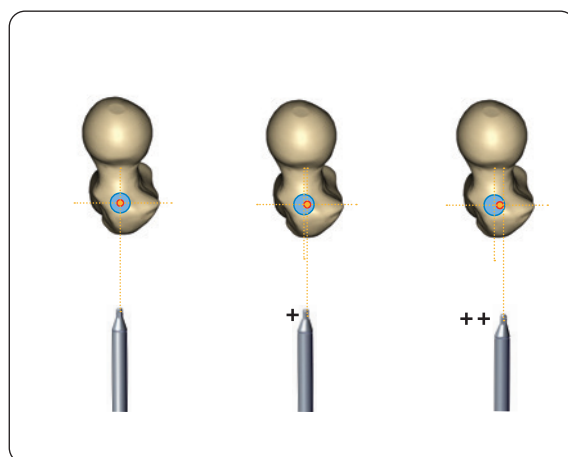

Fig. 14 Cone types entry point C13/C15, C13+/C15+ or C13++/C15++

For 11mm diameter Fitbone TN/TLN nails, 13mm cones are required

For 13mm diameter Fitbone TN/TLN nails, 15mm cones are required

Cones

With perfect kirschner wire placement, insert the centered cone C13 (external diameter 13mm) or C15 (external diameter 15mm). If the position of the kirschner wire has to be corrected, use eccentric cones C13+, C15+ in order to correct 1mm or C13++, C15++ in order to correct 2mm in any direction. A notch at the end of the cone will help in achieving the correct orientation. If correction of more than 2mm is needed remove and re-insert the kirschner wire in the corrected position. Optionally, before inserting the cone over the kirschner wire, slide the tube T14/13-S or -M or tube T16/15-S or -M ("Working Tube") over the cone (Fig. 14).

Cones insertion

For insertion of the cone use the cone sinker CS 15-13 and hammer the tip of the cone into the bone (Fig. 15). The cone should be inserted up to the depth of the teeth to ensure stable positioning. The hexagonal shape of the tip will prevent the cone slipping backwards and in the case of eccentric cone, prevent the cone rotating.



PRECAUTION: Do not directly hammer the cone because that will damage the cone end and tubes will not slide on the cone as required.

REF	Cone Sinker	REF	Cone	REF	Working Tube
60001036	CS 15-13	60001028	C13	60001014	Tube T14/13
		60001029	C13+		
		60001030	C13++		
60001036	CS 15-13	60001060	C15	60001050	Tube T16/15
		60001061	C15+		
		60001062	C15++		

Table 1 Cones, Cone Sinker and Working tube assembly

Tubes

The Fitbone Tubing System has several key functions to assist in delivering a successful surgery. The tubes protect soft tissues, guide the reamers along the planned alignment, assist in the removal of reamed bone debris and protect the bone canal once reamed.

In order to guide the reamers along the planned alignment, tubes are placed in sequence inside one another.

Table 2 provides an overview of which tubes should be used with each reamer.

Please note that at least 0.5mm space is needed between the rigid reamer and the inner diameter of a tube to prevent material from blocking the rigid reamer while reaming.

There are four different tube lengths S (Small), M (Medium), L (Large) and XL (Extra Large). (Fig. 16)

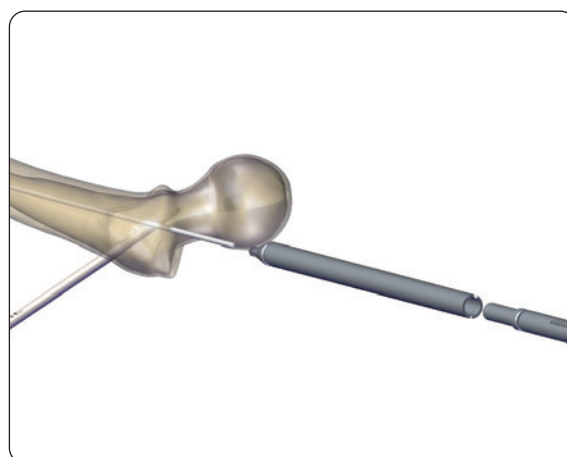

Fig. 15 Cone insertion

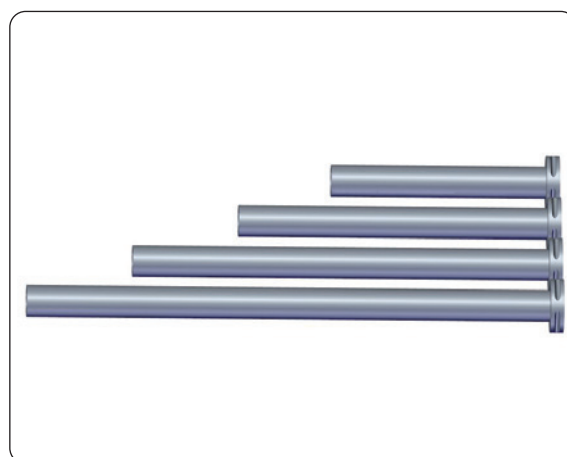

Fig. 16 Tubes (S, M, L and XL)

Depending on the Set provided, not all tubes may be available.

There is the possibility to ream with flexible reamers instead of rigid reamers in cases of no deformity correction or by surgeons' decision.

Tube	S REF	M REF	L REF	XL REF	Rigid Reamer	Front cutting Rigid Reamer REF	Rounded Rigid Reamer REF
Tube T12/09	60001048	60001018	60001022	60001026	Reamer D8.0		60000411
Tube T12/10	60001047	60001017	60001021	60001025	Reamer D9.0	60000412	60000413
Tube T12/11	60001046	60001016	60001020	60001024	Reamer D10.0	60000414	60000415
Tube T13/12	60001045	60001015	60001055	60001059	Reamer D10.5		60000416
					Reamer D11.0	60000417	60000418
Tube T14/13	60001044	60001014	60001054	60001058	Reamer D11.5		60000833
					Reamer D12.0	60000419	60000420
Tube T15/14	Not available	60001051	60001053	60001057	Reamer D12.5		60000716
					Reamer D13.0	60000421	60000422
Tube T16/15	Not available	60001050	60001052	60001056	Reamer D13.5		60000423

Table 2 Tubes and Rigid Reamers assembly

Working tube insertion

Use the tube-sinker TS15 to insert the tube into the bone (**Fig. 17, 18**), according to **Table 3**.

For Fitbone TN/TLN 11, Tube14/13 must be used (short or medium as available)

For Fitbone TN/TLN 13, Tube 16/15 must be used (Short or medium as available)

Tube	S REF	M REF	L REF	XL REF	Tube Sinker	REF
Tube T12/09	60001048	60001018	60001022	60001026	TS 13	60001033
Tube T12/10	60001047	60001017	60001021	60001025		
Tube T12/11	60001046	60001016	60001020	60001024		
Tube T13/12	60001045	60001015	60001055	60001059		
Tube T14/13	60001044	60001014	60001054	60001058		
Tube T15/14	Not available	60001051	60001053	60001057	TS 15	60001064
Tube T16/15	Not available	60001050	60001052	60001056		

Table 3 Tubes and Tube sinker assembly

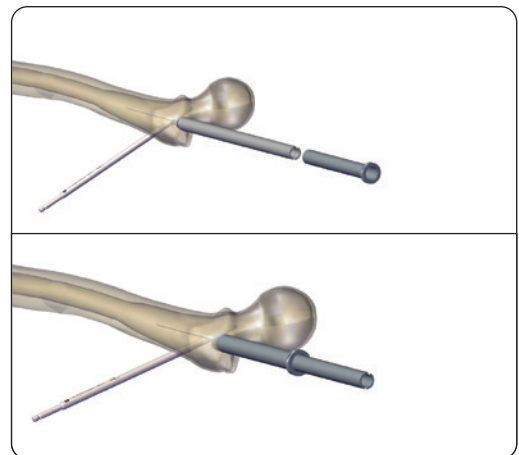

Fig. 17 Working tube insertion

The working tube should be inserted approximately 10-15mm into the bone, making sure the tube is stable inside the bone and the insertion angle of the reamer is orientated according to the anticipated direction of the nail based on preoperative plan.

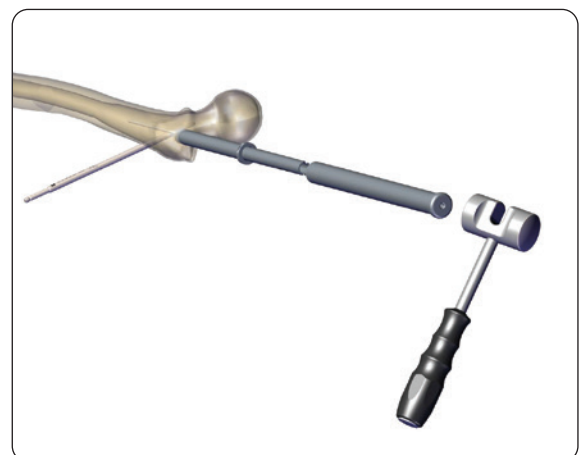

Fig. 18 Working tube insertion

Remove the kirschner wire and the cone, leaving the working tube in place (**Fig. 19**).



WARNING: If an eccentric cone has been used, do not rotate it while removing.

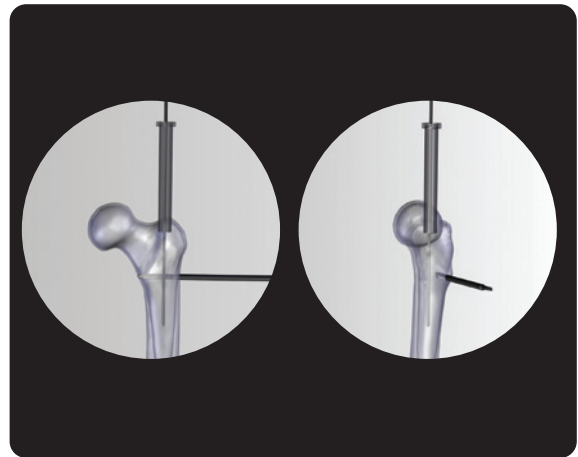

Fig. 19 Working tube final position (AP and lateral view)

INITIAL REAMING

Part #	Description
60000411	Fitbone™ reamer D8.0 L200 L480 rounded
60000413	Fitbone™ reamer D9.0 L200 L480 rounded
60000412	Fitbone™ reamer D9.0 L100 L480 forehead cutting
60000415	Fitbone™ reamer D10.0 L200 L480 rounded
60000414	Fitbone™ reamer D10.0 L100 L480 forehead cutting
60000416	Fitbone™ reamer D10.5 L200 L480 rounded
60000418	Fitbone™ reamer D11.0 L200 L480 rounded
60000417	Fitbone™ reamer D11.0 L100 L480 forehead cutting
60000833	Fitbone™ reamer D11.5 L200 L480 rounded
60000420	Fitbone™ reamer D12.0 L200 L480 rounded
60000419	Fitbone™ reamer D12.0 L100 L480 forehead cutting
60000716	Fitbone™ reamer D12.5 L200 L480 rounded
60001179	Fitbone™ step reamer TAA1180
60001415	Fitbone™ step reamer TAA1160
60001528	Fitbone™ step reamer TAA1140
60000421	Fitbone™ reamer D13.0 L100 L480 forehead cutting
60000422	Fitbone™ reamer D13.0 L200 L480 rounded
60000423	Fitbone™ reamer D13.5 L200 L480 rounded
60000392	Fitbone™ T-handle

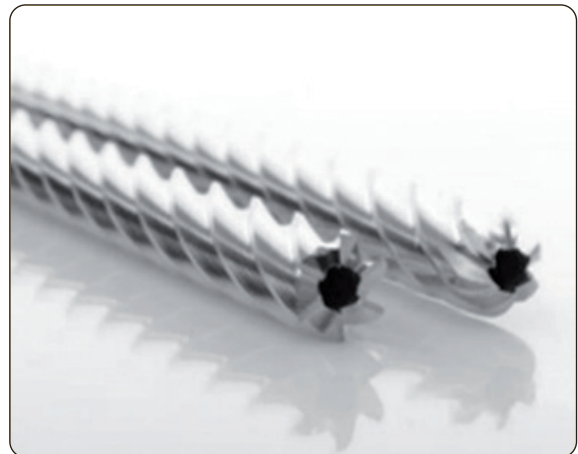

Fig. 20 Front cutting reamer (Left), rounded reamer (Right)

The Fitbone Transport and Lengthening System includes flexible and two different types of rigid reamers (**Fig. 20**):

1. Rounded reamer (Fitbone reamer rounded)
2. Front cutting reamer (Fitbone reamer forehead cutting)

The rounded rigid reamers have a cutting length of 200mm and are used to open and straighten the medullary cavity. To secure the entry point at all times and to avoid unintended displacements, the use of tubes is strongly recommended.

The front cutting rigid reamers with a cutting length of 100mm make it possible to open and correct medullary cavity reaming in any direction.



WARNING: There is a risk of excessive cortical weakening and even perforation, leading to a fracture during treatment, particularly with the front cutting reamers.

REAMING OF THE MEDULLARY CAVITY WITH RIGID REAMERS

Insert the 12mm front cutting rigid reamer through the working tube and ream the tube to a depth of 2cm.

Reduce tube diameter for concentric reaming by inserting the tubes T13/12 and T12/09 or T12/10 in case of 11mm nails (Fig. 21). By 13mm nails insert the tube 15/14, 14/13, 13/12 and T12/09 or T12/10. Ream with an 8mm or 9mm rounded rigid reamer up to the planned end of the nail, indicated by the skin marker, and assisted by AP and lateral fluoroscopy.



PRECAUTION: Monitor the entire reaming process with the image intensifier in two planes to detect any reaming errors in time.

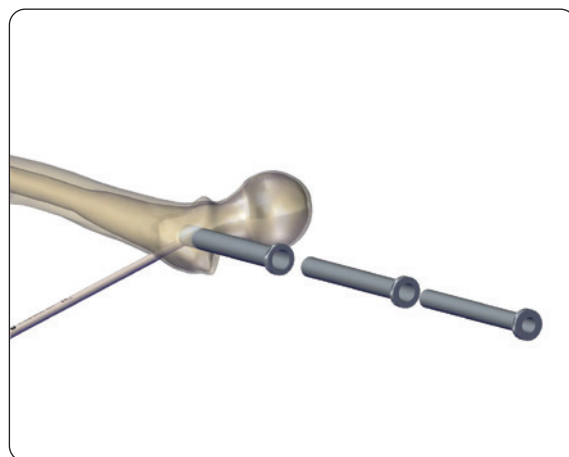

Fig. 21 Reducing the reaming channel

Tubes

The proximal segment corresponds to the proximal section of the nail, with a larger diameter.

Ream the proximal segment as follows (Fig. 22):
For $\varnothing 11$ nail, continue with 10mm, 11mm and finally with 12mm rigid reamer, changing the inner tubes corresponding to the rigid reamer in use, see also **Table 2**.

There is also a 12.5mm rigid reamer available if required.

For $\varnothing 13$, continue with 10mm, 11mm, 12mm and finally with the 13mm rigid reamer, changing the inner tubes corresponding to the rigid reamer in use, see also **Table 2**.

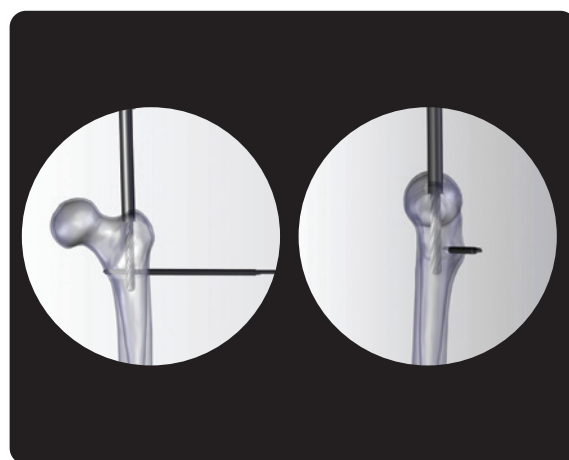

Fig. 22 Reaming of proximal segment

There is also a 13.5mm rigid reamer available if required.

Double-check the canal after each reaming with AP and lateral fluoroscopy.

The inner tube diameter is the smallest number and the outer diameter the largest, e.g. 13/12 means 13mm outer and 12mm inner diameter.

Reaming of distal segment

The distal segment corresponds to the distal section of the nail, with a smaller diameter.

Ream the distal segment as follows:

For $\varnothing 11$, gradually ream from 8mm or 9mm up to 11mm using rigid rounded reamers.

For $\varnothing 13$, gradually ream from 8mm or 9mm up to 13mm, using rigid rounded reamers.



PRECAUTION: Do not weaken the cortex as this could increase the risk of fracture during treatment (Fig. 24).

If the correct position cannot easily be reached, use the front cutting rigid reamers to widen the midshaft canal posteriorly.

The front cutting rigid reamer will aggressively remove part of the posterior cortex thus the process has to be controlled under AP and lateral fluoroscopy very carefully at all times.



WARNING: Never use front cutting rigid reamers in the area of the final position of the tip of the Fitbone intramedullary nail.

Step reamer TAA

For Fitbone TN/TLN 11 the final ream is performed using the appropriate step reamer (Fig. 23). Perform reaming by hand, using the T-handle in order to achieve better control. The canal should be reamed up to the point where the change in diameter of the step reamer correspond to where the change in diameter of the implant is going to be, which should be already marked on the skin. (Fig. 23a, 23b)

For every implant size, there is a step reamer TAA that can be used (see table 4).

The step reamer should be used with the working tube T14/13 for $\varnothing 11$.

In case of $\varnothing 13$ nails, the final reamer to be used is the $\varnothing 13$ mm reamer. If needed, ream with the 13.5mm reamer may necessary if bone is sclerotic. There is no step reamer since the nail is $\varnothing 13$ mm along the entire length.



Fig. 23 Reaming of distal segment and step reamer

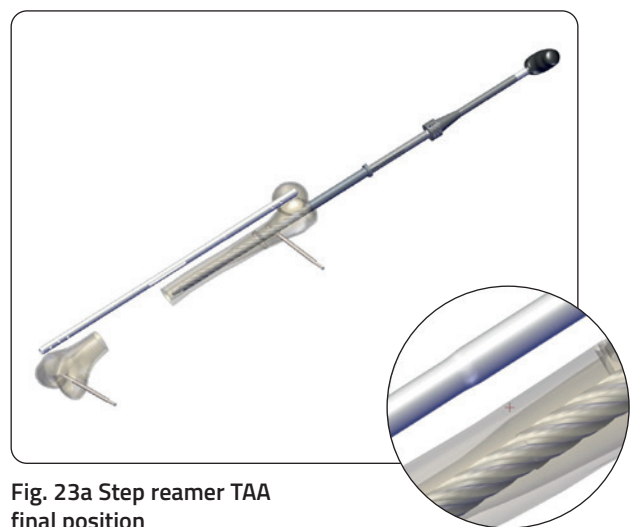

Fig. 23a Step reamer TAA final position

Fig. 23b Level of the change in diameter of the nail

Fitbone TN/TLN	Step Reamer TAA	REF
Fitbone TRANSPORT NAIL TN 1140-F-A-XXX Fitbone TRANSPORT LENGTHENING NAIL TLN 1140-F-XX-XXX	Step Reamer TAA1140	60001528
Fitbone TRANSPORT NAIL TN 1160-F-A-XXX Fitbone TRANSPORT LENGTHENING NAIL TLN 1160-F-XX-XXX	Step Reamer TAA1160	60001415
Fitbone TRANSPORT NAIL TN 1180-F-A-XXX Fitbone TRANSPORT LENGTHENING NAIL TLN 1180-F-XX-XXX	Step Reamer TAA1180	60001179
Fitbone TRANSPORT NAIL TN 13XX-F-A-XXX Fitbone TRANSPORT LENGTHENING NAIL TLN 13XX-F-XX-XXX	Reamer D 13.0 L200 L480 rounded	60000422

Table 4 Overview Fitbone TN/TLN and Step Reamer TAA

EXTRACTING THE WORKING TUBE

Part #	Description
60001038	Fitbone™ clamp

The working tube is removed using the tube extractor clamp (Fig. 24).

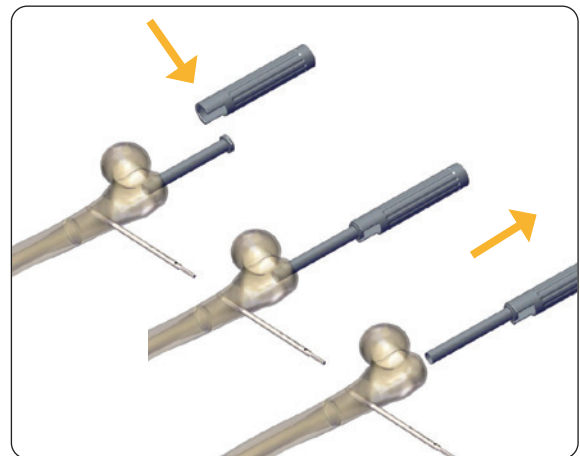

Fig. 24 Extracting the working tube

APPROACH AND INITIAL REAMING WITH FLEXIBLE REAMERS

Part #	Description
172991	Flexible Reamer System Box
99-173281	Guide Wire with Olive Ø3x980mm
173230	reamer sleeve
183260	Awl
60001039	FITBONE KIRSCHNER WIRE D3 L280

Locate the greater trochanter by palpation or under x-rays. A longitudinal skin incision (approximately 4cm) is made proximal to the greater trochanter.

Insert the kirschner wire into the intramedullary canal, via the piriformis fossa using fluoroscopy in AP and lateral view (**Fig. 25**).

Insert the tissue protector (reamer sleeve) over the kirschner wire at the level of the entry point followed by the awl.

Open the entry point by gently advancing the awl or an entry reamer over the kirschner wire with a twisting motion up to the marked part (**Fig. 26**).

Remove the awl, the kirschner wire and the tissue protector (reamer sleeve). A 3x980mm guide wire with olive is inserted into the medullary canal, and its position confirmed in both planes. Proceed with proximal reaming of the medullary canal.

Ream with a 8mm or 9mm flexible reamer up to the planned end of the nail, indicated by the skin marker, and assisted by AP and lateral fluoroscopy. Increase reaming gradually of 0.5mm increments, until the intramedullary channel is overreamed by 2mm (**Fig. 27**).



PRECAUTION: Monitor the entire reaming process with the image intensifier in two planes to detect any reaming errors in time.

Reaming of proximal segment (only for 9 and 11mm nails)

The proximal segment corresponds to the proximal section of the nail, with a larger diameter (12mm), which is marked on the skin with a stapler.

Ream the proximal segment as follows:

Increase reaming gradually of 0.5mm increments, until the intramedullary channel is overreamed by 2mm according to the size of the nail, up to 14mm.

Double-check the canal after each reaming with AP and lateral fluoroscopy.



PRECAUTION: Do not weaken the cortex as this could increase the risk of fracture during treatment.

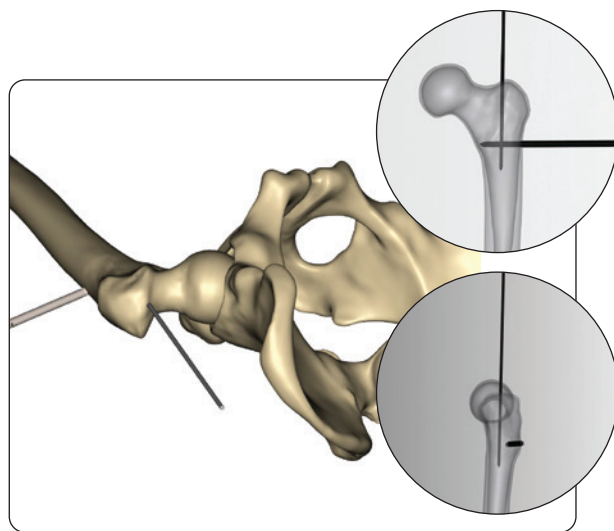

Fig. 25 Kirschner wire insertion

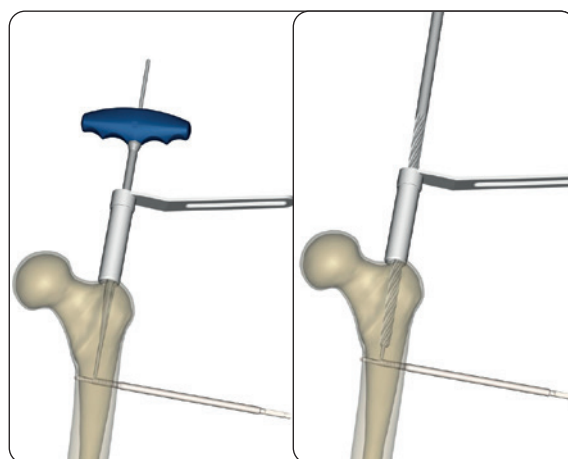

Fig. 26 Awl

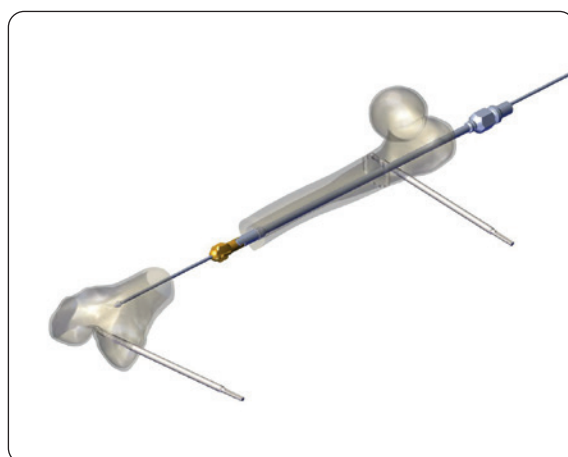

Fig. 27 Reaming of intramedullary channel

OSTEOTOMY

In case the reaming was performed with flexible reamers, make sure to remove the guide wire with olive, before performing the osteotomy.

Perform percutaneous osteotomy at the previously marked level (**Fig. 28**). Ensure that the osteotomy is completed before continuing.





Once the osteotomy has been performed, manipulate the limb into the correct alignment according to the preoperative plan (Reverse Planning Method). Ensure correct rotational alignment of the limb by keeping the reference half-pins parallel in case of no torsional deformity. An external fixator can be attached to the half-pins to retain the corrected alignment.

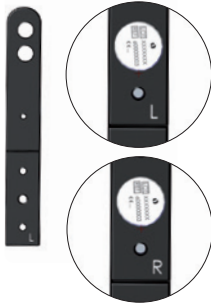

Fig. 28 Osteotomy

DUMMY TAA/TRIAL NAIL TN/TLN AND JIG ASSEMBLY

Part #	Description
99-6000xxxx	FITBONE TRANSPORT TRIAL NAIL
99-6000xxxx	FITBONE TRANSPORT LENGTHENING TRIAL NAIL
60001248	Dummy TAA 1140-F-205
60001139	Dummy TAA1160-F-225
60000822	Dummy TAA 1180-F-245
60001623	Dummy TAA 1380-F-245
60000689	Fitbone™ open end wrench SW14/17
60000688	Fitbone™ test pin D4.5
60001184	Fitbone™ outrigger TAA
60000175	Fitbone™ fastening bolt M6 L9
60001175	Fitbone™ drill guide TAA
60000218	Fitbone™ space holder TAA
60000310	Fitbone™ connection bolt TAA
60000219	Fitbone™ clamping nut TAA
60000003	Fitbone™ setscrew

Fitbone Drill Guide TAA	Fitbone Outrigger TAA	Fitbone Space Holder TAA	Fitbone Clamping Nut TAA	Fitbone Connection Bolt TAA
				
The Fitbone drill guide TAA is bilateral since it can be used for left leg "L" or right leg "R"	The Fitbone outrigger TAA is the main body of jig	The Fitbone space holder is the part of the jig to which the Fitbone dummy/nail will be assembled and it has a notch that is used as a reference mark to correctly position the Fitbone into the bone.	The Fitbone clamping nut is used to fix the space holder into the outrigger TAA.	The Fitbone connection bolt TAA is used to fix the dummy/nail through its thread

If a check of the proper assembly of the jig is preferred, the drill guide can be attached and the check can be performed.

Attach the drill guide to the outrigger, paying attention to the indication "L" and "R" (**Fig. 29**) and lock it in place. (**Fig. 30**)

For the antegrade approach mark "L" for the right leg and "R" for the left leg.

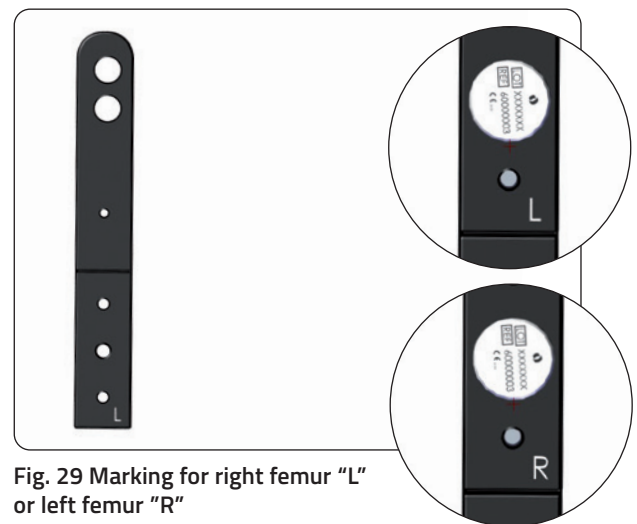

Fig. 29 Marking for right femur "L" or left femur "R"

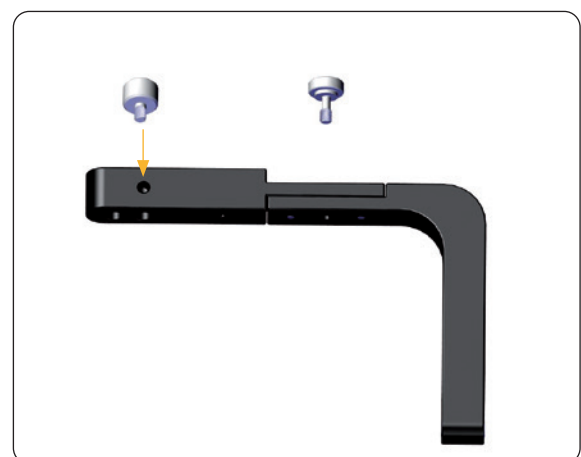

Fig. 30 Drill guide fixation

Assembly space holder

Insert the Space Holder into the squared hole in the back of the handle, making sure that the marking "THIS SIDE UP" is facing upwards, and lock it by hand using the clamping nut. (Fig. 31)

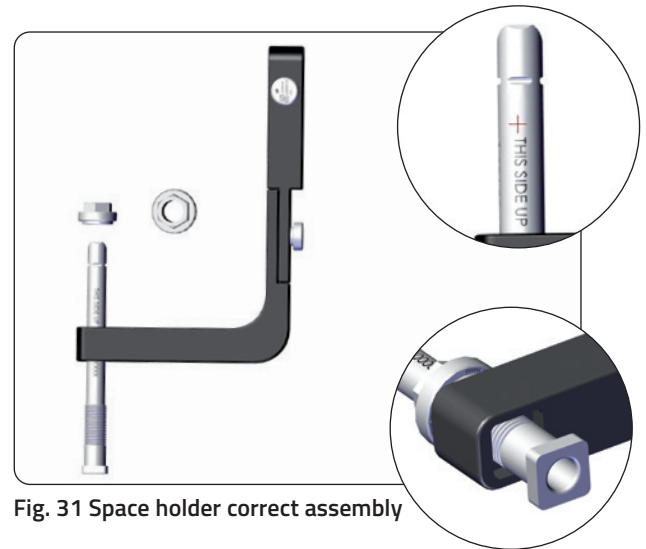

Fig. 31 Space holder correct assembly

Insert the "connection bolt" into the "space holder" and fix the assembly by screwing the "clamping nut" on the thread of the "space holder". (Fig. 32)

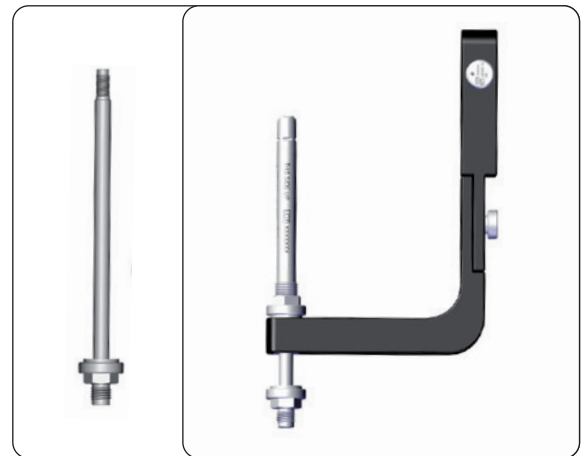

Fig. 32 Space holder fixation

INSERTION OF THE DUMMY TAA/TRIAL NAIL TN/TLN

The trial nail TN/TLN is used to confirm the medullary canal is appropriately prepared for the Fitbone™ nail to be implanted. It must be possible to insert the nail without resistance and without hammering.

The trial nail TN/TLN should be connected to the jig (Fig. 33) and inserted to confirm the final nail can be implanted at the planned depth (5-10mm below bone entry point) and alignment.

The dummy nail TAA can be used to place blocking screws if required. It can also be useful to confirm the fitting of the proximal part of the TN/TLN nail into the bone since the geometry of TAA and TN/TLN at the proximal part is the same.

Refer to **Table 4** for the correct combination of dummy TAA and step reamer TAA, based on the selected FITBONE TN/TLN.



Fig. 33 Trial nail TN/TLN assembly

Trial nail TN/TLN insertion

Insert the Trial nail TN/TLN to confirm planned nail position is achieved. The drill guide portion of the jig can be removed for better visualization under x-ray.

Ensure the space holder marker on the jig is at the level of the entry point. This indicates that the nail is sufficiently implanted in the bone, to a depth of 5-10mm. It is advised to check nail positioning under fluoroscopy in AP and lateral planes. (Fig. 34)

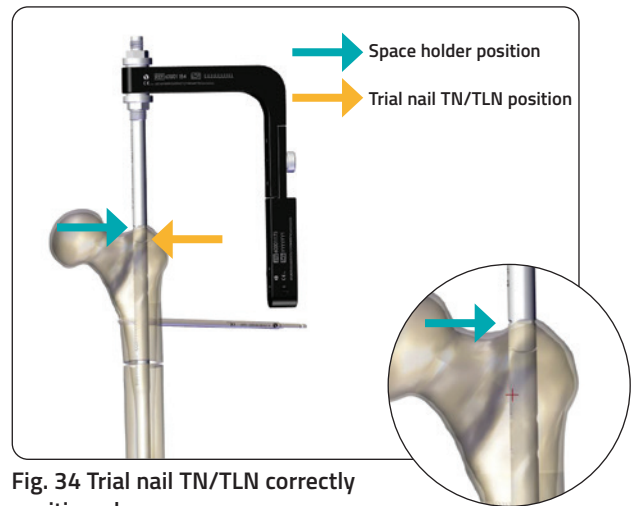

Fig. 34 Trial nail TN/TLN correctly positioned

POTENTIAL PROBLEMS AND SOLUTIONS

1. The marking "THIS SIDE UP" on the Space Holder is not facing upwards and the connection between drill guide assembly and nail is loose. (Fig. 35)

Corrective action: Place the Space Holder correctly with "THIS SIDE UP" facing upwards.

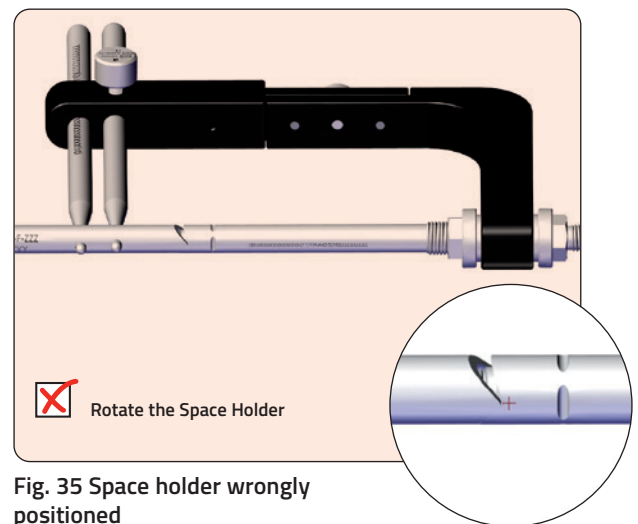

Fig. 35 Space holder wrongly positioned

2. The Space Holder is not completely flush with the Drill Guide Assembly (Fig. 36).

Corrective action: Insert the Space Holder correctly, making sure that the squared end is placed into the square hole in the back of the handle.

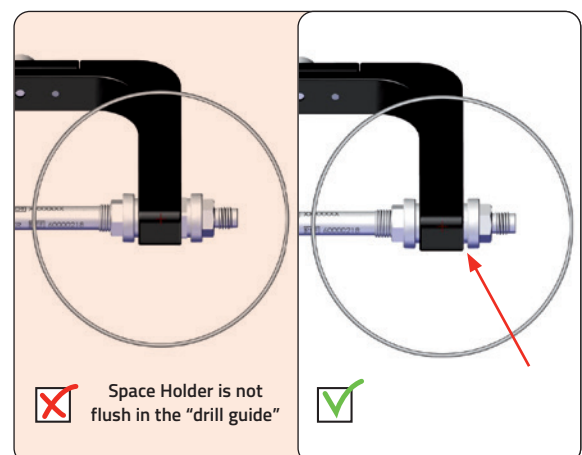

Fig. 36 Space holder wrongly inserted

3. The dummy/trial nail is wrongly placed. (Fig. 37)

Corrective action: Unlock the "Connection Bolt" and rotate the nail 180°.

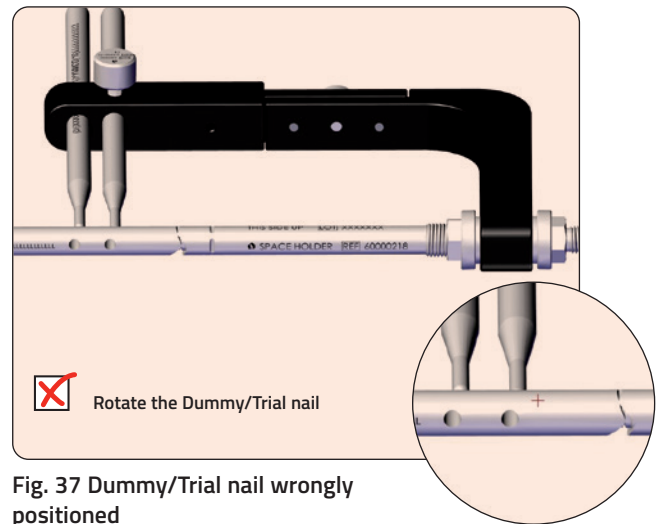

Fig. 37 Dummy/Trial nail wrongly positioned

4. The dummy/trial nail is loosely fixed to the "connection bolt". (Fig. 38)

Corrective action: Tighten the Connection Bolt firmly. The fixation has to be tight.

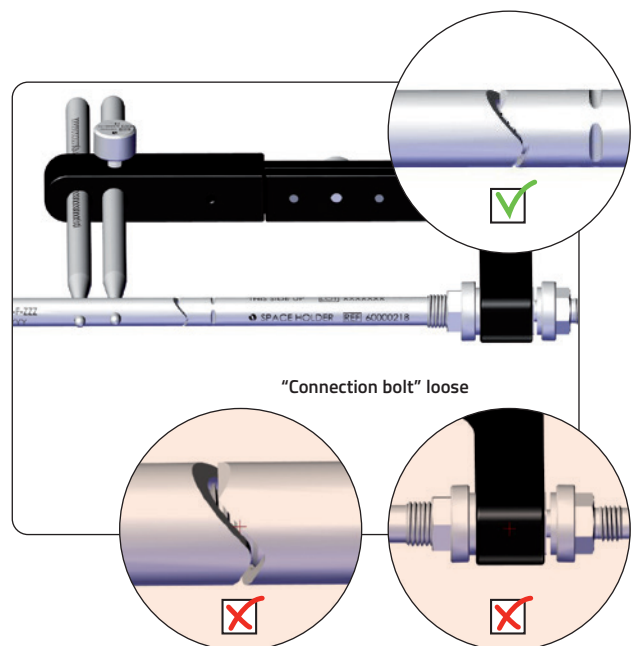

Fig. 38 Connection Bolt loose

BLOCKING SCREWS INSERTION

Part #	Description
60000406	Fitbone™ screwdriver SW3.5 cannulated
60000576	Fitbone™ screwdriver SW3.5
60000384	Fitbone™ screw holder M2 L325

The use blocking screws to achieve correct alignment is recommended. The anterior-posterior (to the nail) screw maintains correct alignment in the lateral view while the medial-lateral screw maintains alignment in the AP view (to the nail) (Fig. 39).

If blocking screws are needed, insert the regular Fitbone 4.5mm screws.

In order to place the blocking screws use the Fitbone TN or TLN trial nail, if available, otherwise you can use the TAA dummy nail that most resembles the chosen Fitbone TN or TNL nail. See table 5

When using a trial TN/TLN make sure that the distal and proximal fragments are aligned correctly and final stabilization of the Fitbone TN/TLN nail is ensured.

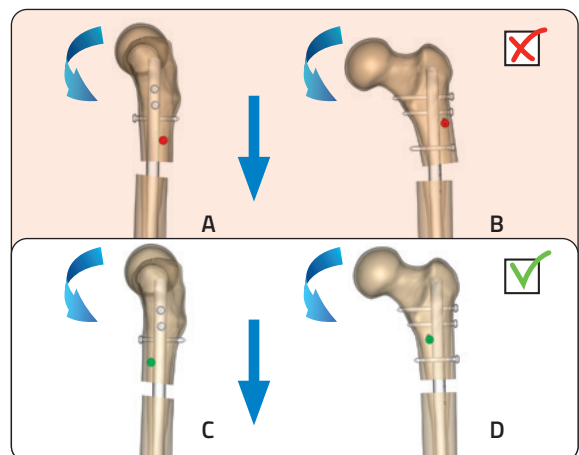

Fig. 39 Alignment and blocking screws



PRECAUTION: Perform additional corrections or place blocking screws only with the dummy / trial nail inside the bone, never while the Fitbone intramedullary nail is inserted.

Fitbone TN	Fitbone TLN	Step Reamer TAA	REF	Dummy TAA	REF
Fitbone TN 1140-F-A-XXX	Fitbone TLN 1140-F-XX-XXX	Step reamer TAA1140	60001528	Dummy TAA1140-F-205	60001248
Fitbone TN 1160-F-A-XXX	Fitbone TLN 1160-F-XX-XXX	Step reamer TAA1160	60001415	Dummy TAA1160-F-225	60001139
Fitbone TN 1180-F-A-XXX	Fitbone TLN 1180-F-XX-XXX	Step reamer TAA1180	60001179	Dummy TAA 1180-F-245	60000822
Fitbone TN 13XX-F-A-XXX	Fitbone TLN 13XX-F-XX-XXX	Reamer D13.0 L200 L480 rounded	60000422	Dummy TAA1380-F-245	60001623

Table 5 Overview Fitbone TN/TLN, Step Reamer TAA and Dummy TAA

Alignment Control

Remove the jig, leaving the trial nail in place. Place the leg in full extension and control alignment with the double line grid as described previously. (Fig. 40)

The double line should be centred on the hip, and ankle joint, passing the knee joint as planned (RPM). Perform additional reaming or correction alignment if needed.

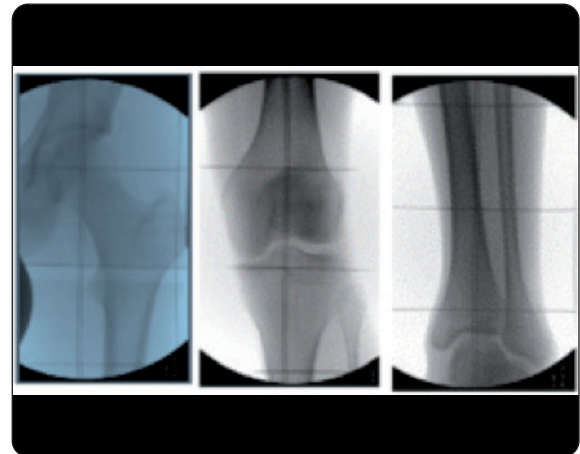

Fig. 40 Alignment control

REMOVAL OF THE RECHARGING SCREW

Part #	Description
99-10013	Allen Wrench 3mm Sterile (Single Use)

In case the whole stroke of the nail will be needed during the treatment and no retraction of the nail is expected, the recharging screw should be removed by using the Allen Wrench.

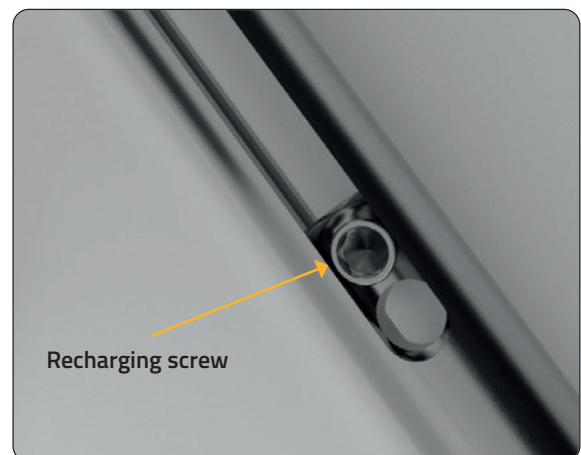

Fig. 41 Recharging screw

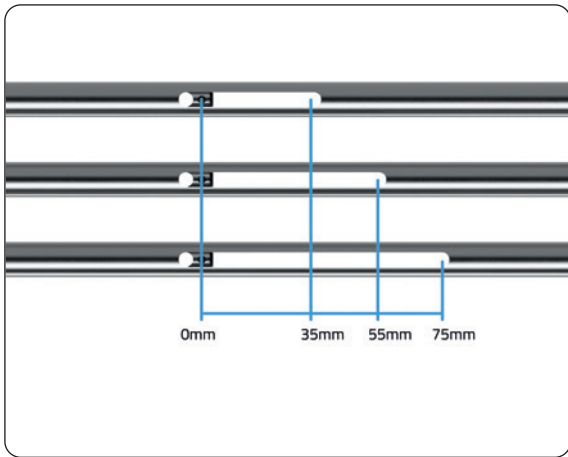

Fig. 42 Available stroke with recharging screw assembled

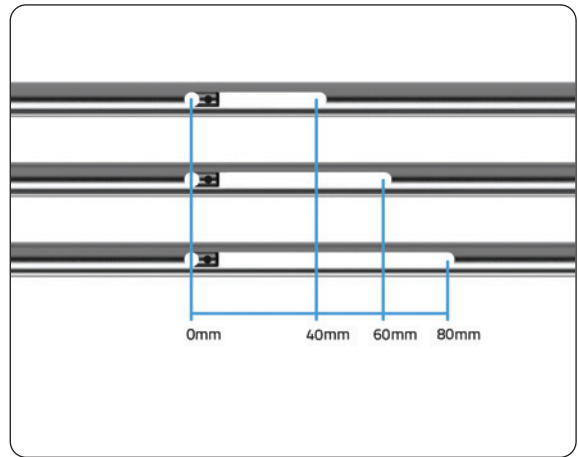

Fig. 43 Available stroke without recharging screw

INSERTION OF THE FITBONE TN/TLN

Part #	Description
60000689	Fitbone™ open end wrench SW14/17
60000688	Fitbone™ test pin D4.5
60001184	Fitbone™ outrigger TAA
60000175	Fitbone™ fastening bolt M6 L9
60001175	Fitbone™ drill guide TAA
60000218	Fitbone™ space holder TAA
60000310	Fitbone™ connection bolt TAA
60000219	Fitbone™ clamping nut TAA
60000003	Fitbone™ setscrew

Insert the cable of the Fitbone nail carefully into the connection bolt and attach the Fitbone nail to the Jig (**Fig. 44**). Attach the drill guide to the outrigger and insert the test pins D4.5 into the drill guide and make sure that they pass through the holes in the nail easily without friction. Refer to page 13 for potential problems and solutions.

Lock the nail firmly in place using two open end wrenches SW14/17 simultaneously (**Fig. 45**). Remove the test pins.

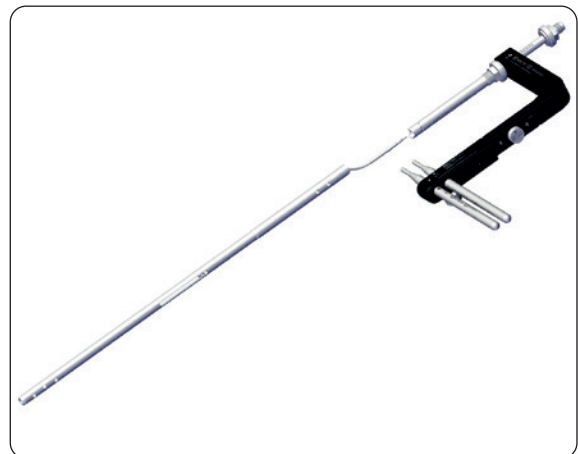

Fig. 44 Final nail assembly

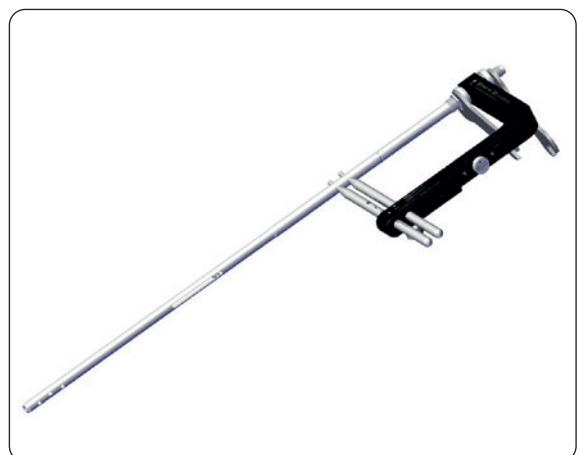

Fig. 45 Final nail locking

Insert the nail into the femur, making sure that the marking notch is at the level of the entry point (**Fig. 46**) or 5mm outside the bone, so that the nail is inserted into the bone deep enough.



WARNING: Never use a hammer to drive or remove the Fitbone Nail into/from the medullary cavity since this could damage the implant.

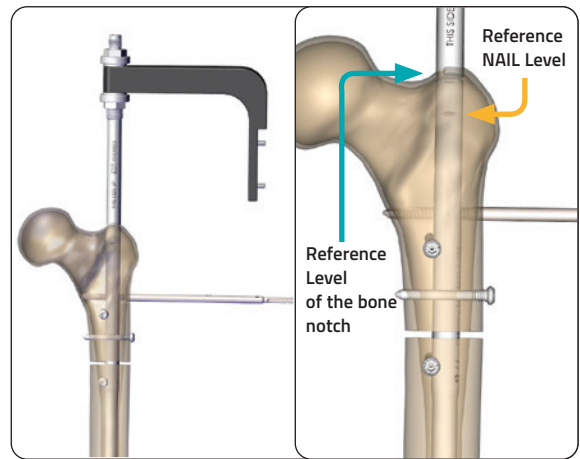

Fig. 46 Nail insertion

Inserting the proximal locking screws

Part #	Description
60000402	Fitbone™ drill sleeve D8.0 green
60000400	Fitbone™ Drill sleeve D4.5 black
60000403	Fitbone™ trocar D4.5
60000405	Fitbone™ trocar D4.5 T-handle
60000408	Fitbone™ depth gauge
60000398	Fitbone™ drill bit D4.5 L300
60000406	Fitbone™ screwdriver SW3.5 cannulated
60000576	Fitbone™ screwdriver SW3.5
60000384	Fitbone™ screw holder M2 L325

The proximal screws have a diameter of 4.5mm in all Fitbone TN/TLN. They are available in long and short threaded options. Select the longest thread possible without interaction between thread and nail occurring. Insert the drill sleeve D8.0 green together with a drill sleeve D4.5 black and the trocar D4.5 into one of the two holes in the drill guide. Insert the sleeves with the trocar through the lateral incision splitting the soft tissue (**Fig. 47**).

Drill bi-cortically and use the depth gauge to measure the correct screw length.

Select the correct screw and introduce through the the drill sleeve D8.0 green, using the screwdriver SW3.5 cannulated.

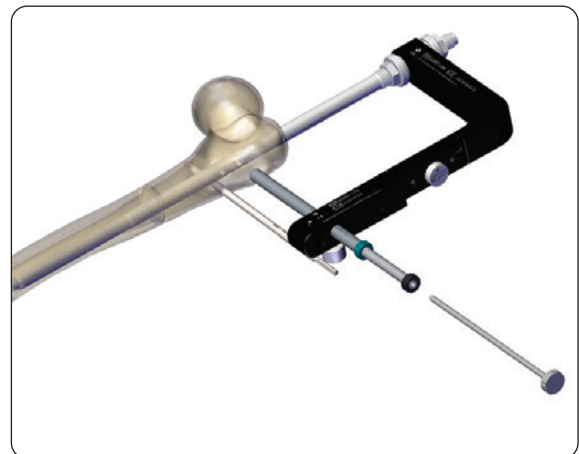

Fig. 47 Drill sleeve insertion

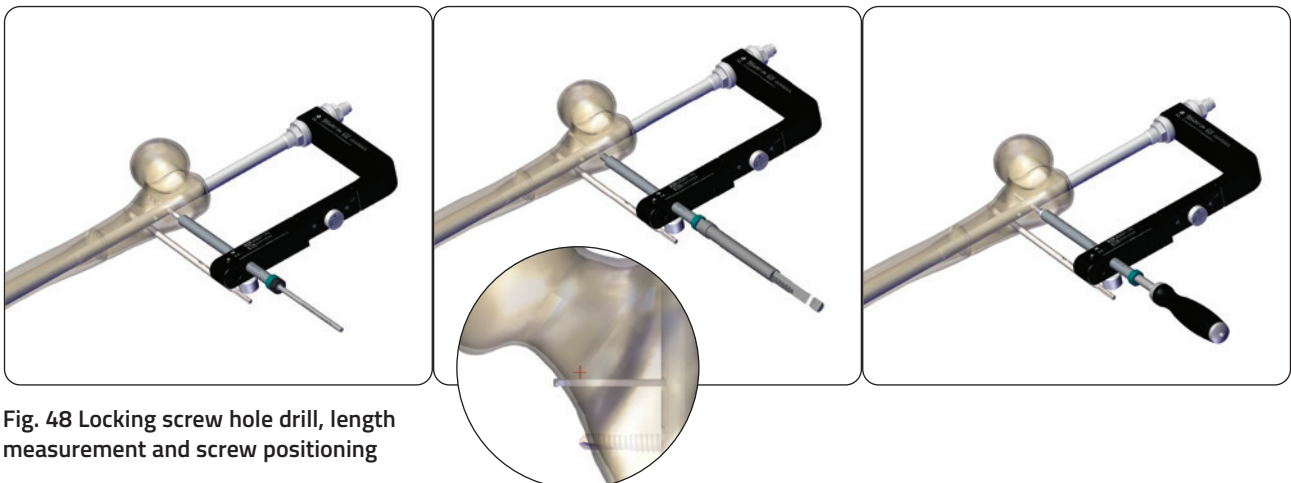

Fig. 48 Locking screw hole drill, length measurement and screw positioning

Once it can be felt that the thread has engaged the bone, disengage the screwdriver SW3.5 cannulated and complete the tightening with the screwdriver SW3.5 (**Fig. 48**).

Insert the second proximal locking screw using the same procedure.

Check correct both screw position and length under fluoroscopy in AP and lateral planes.



Fig. 49 Drilling for distal screw

Inserting one distal locking screw

Before performing distal locking check that both half-pins are parallel to avoid torsional misalignment. The first distal locking screw is inserted using the free-hand technique under fluoroscopy (**Fig. 49 and 50**). Drill bi-cortically using the drill bit D4.5 L300 and measure the screw length with the depth gauge.

4.5mm screws with two thread options are used for all 11 and 13 Fitbone TN/TLN variants. The longest thread possible, without interaction between nail and thread should be selected.

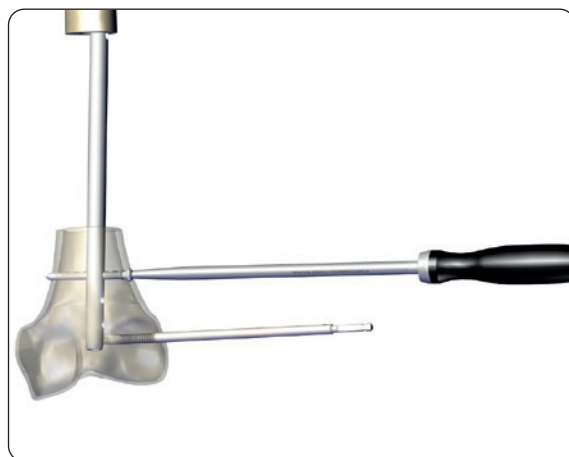

Fig. 50 Distal screw positioning

Inserting the bone transport screw

Drill bi-cortically using the appropriate drill, according to the pre-operative plan, and measure the screw length with the depth gauge.

For this step use the 4.5mm screws available in the system for all 11 and 13 Fitbone TN/TLN variants.

The bone transport screw is inserted using the free-hand technique under fluoroscopy (**Fig. 51**).

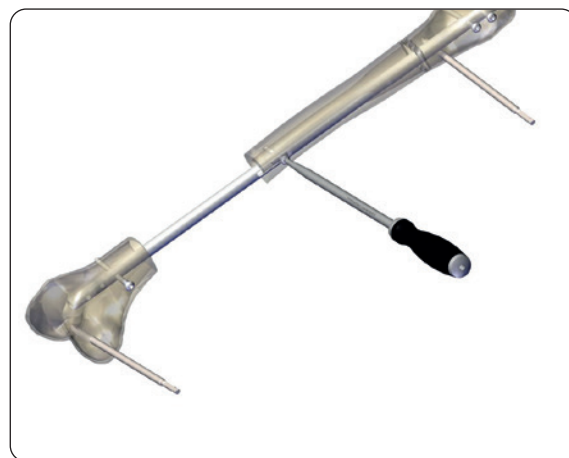

Fig. 51 Transport screw insertion

Inserting of additional distal locking screws

Additional distal locking screws are inserted using the same technique of the first distal screw (Fig. 52).

Fitbone Transport and Lengthening nail (TLN)

A maximum of two or three distal screws can be inserted, depending on the size.

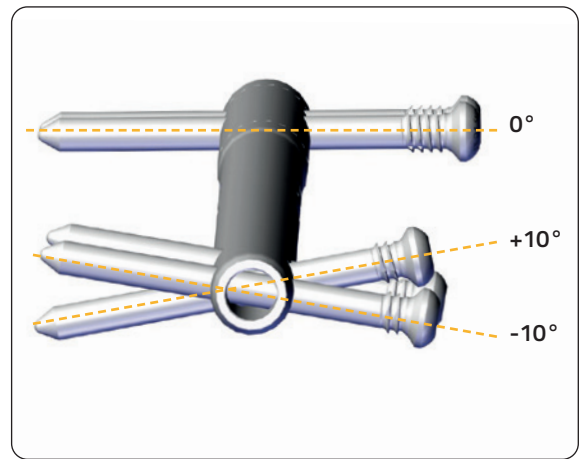

Fig. 52 Additional distal screw positioning

Fitbone Transport nail (TN)

A maximum of three distal screws can be inserted.

Insert at least two distal screws to guarantee system stability (Fig. 53).

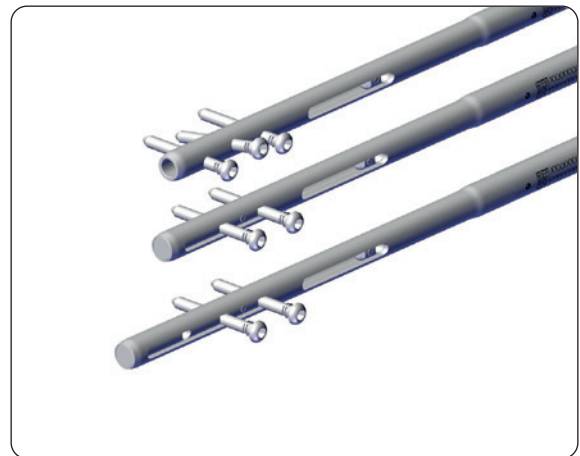

Fig. 53 Distal fixation

The reference half-pins can now be removed.

Jig removal

Part #	Description
60000689	Fitbone™ open end wrench SW14/17

A maximum

Use the wrench to loosen the connection bolt on the jig (Fig. 54).

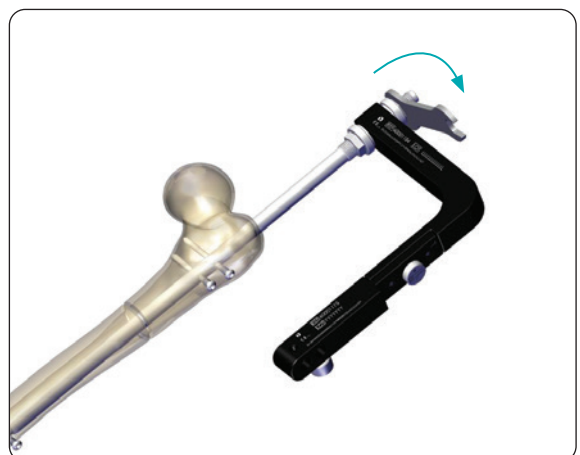

Fig. 54 Loosening the nail

Carefully remove the jig without damaging the cable (Fig. 55).

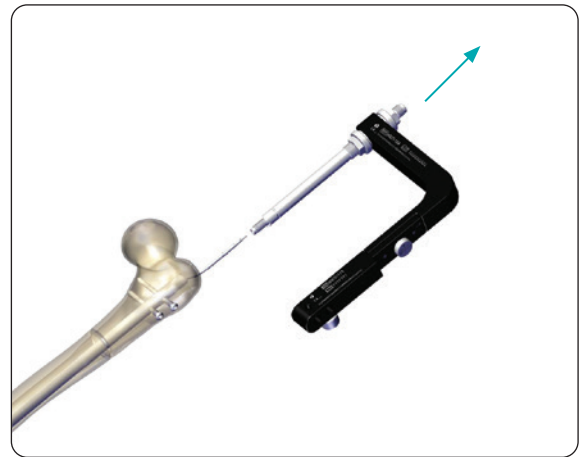

Fig. 55 Removing the jig

Positioning the Receiver

Part #	Description
60001780	Fitbone subcutaneous energy receiver
60001622	Biotronik Torque Wrench 395121

Clean the plug of the cable properly in order to remove any blood (as it can act as an isolator). Remove the transport locking device from the receiver's coupling. Place a drop of sterile water on the plug of the cable and insert into the coupling (Fig. 56).



PRECAUTION: Make sure the white ring (see blue circle in Fig. 53) is in connection with the start of the coupling.

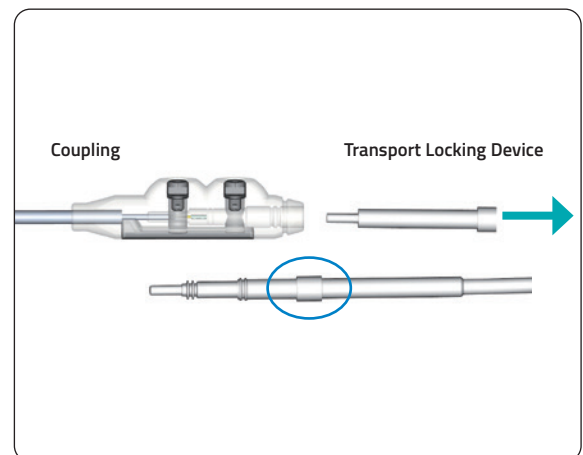

Fig. 56 Transport locking device removal

Lock the cable into the Receiver's Coupling by tightening both screws with the torque wrench, until an audible click is heard (Fig. 57).



PRECAUTION: Do not hold the coupling or cable with surgical instruments and avoid bending the coupling or cable as this can lead to damage or unwanted disconnection.

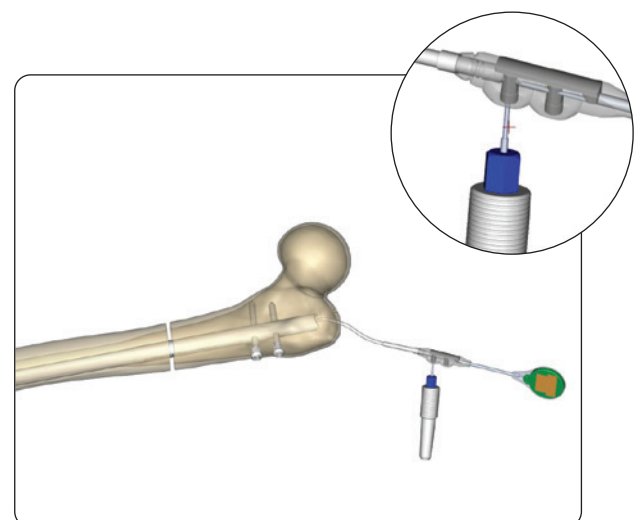

Fig. 57 Receiver connection

The receiver should be placed antero-lateral directly underneath the skin. For this purpose, use scissors to prepare an 80 to 100mm subcutaneous skin pocket (Fig. 58).



PRECAUTION: Power transfer is optimal at approximately 5mm distance from the receiver. Avoid distances of more than 10mm under the skin as such distances can negatively affect the function of the treatment system.

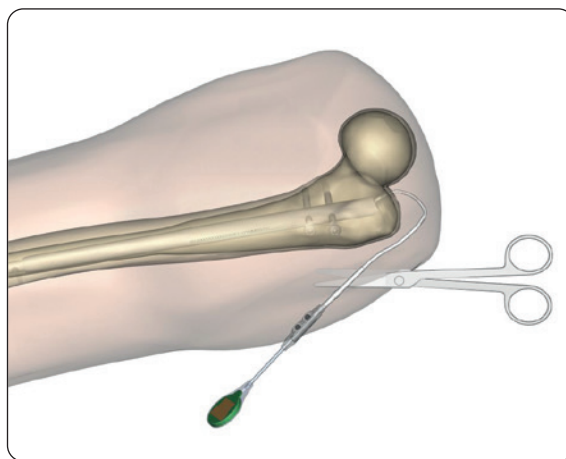

Fig. 58 Subcutaneous skin pocket

Mark the receiver on the surface of the skin (Fig. 59).

FINAL INTRAOPERATIVE TEST

Part #	Description
60001644	Fitbone Control Set for activation of intramedullary lengthening nail US plug 115V
60000676	Kawe stethoscope 06.10100.94

Upon skin closure, perform an intraoperative functionality test as described above.

Place the transmitter and the stethoscope in separate sterile endoscopic camera drapes (Fig. 62, 63). Perform a final functional test, ensuring the motor of the Fitbone can be heard during bone transport.

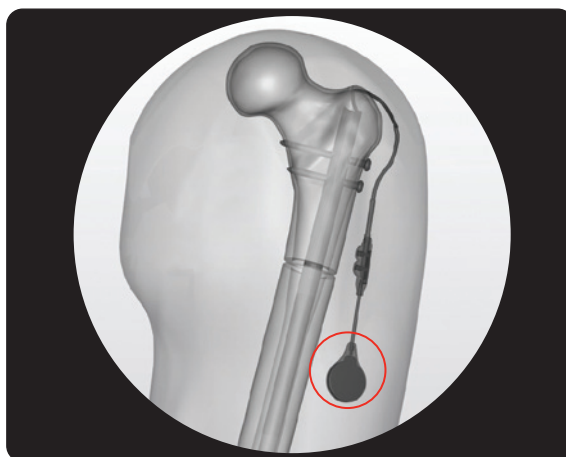

Fig. 59 Receiver final position

Control set settings for intraoperative test

Remove the switch cover cap from the control set. The surgeon can now choose between the patient/doctor mode respectively labelled "Pat" and "Doc" and pulse or permanent operation, respectively labelled "Pulse" and "Perm" (Fig. 60).

In the "Doc" position, the switch labelled "Doctor" on the front is enabled as well as the Pulse and Continuous modes (Fig. 61).

Pressing the "Doctor" button while in the "Doc" and "Pulse" position will result in a continuous repetition of 1 second energy transmission and 9 sec break, until released. Pressing the "Doctor" button while in the "Doc" and "Perm" position will result in a continuous energy transmission until released. This leads to a distraction rate of up to 2mm per minute. This mode can be used to preset the implant or to allow a new locking position for distal locking. Use of continuous operation mode must be interrupted after



Fig. 60 Control Set settings

a maximum of 1 minute for a minimum of 2 minutes to prevent excessive heat in the tissue between the transmitter and receiver. In doctor mode continuous operation, the transmitter can reach a maximum temperature of 47.2°.

In the "Pat" position, the button labelled "Patient" on the front is enabled. In the "Pat" position, the permanent mode is blocked and will not lead to energy transmission.

Pressing the "Patient" button while in the "Pat." and "Pulse" position will result in a 90 second distraction cycle consisting of 9 repetitions of 1 second energy transmission and 9 sec pause between each distraction. Pressing the "Patient" button while in the "Pat." and "Perm" position will not result in any energy transmission.

More information about the function and operation can be found in the instructions for use Fitbone Control Set.

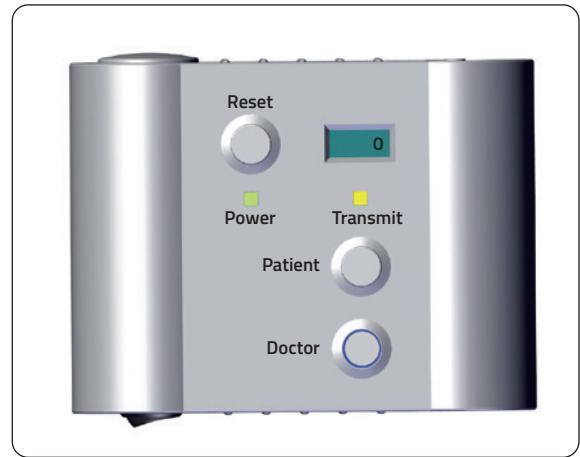

Fig. 61 Control Set



Fig. 62 Inserting the transmitter in the sterile endoscopic camera drape



Fig. 63 Transmitter sterile covered

For the intraoperative test, the doctor ("Doc.") and pulsating ("Pulse") settings are recommended. For the intraoperative final test, connect the transmitter to the Fitbone Control Set and place it on the skin directly above the receiver. Place the stethoscope on the patella. In the recommended settings, press the "Doctor" button and use the stethoscope to confirm correct functioning of the motor (**Fig. 64 and 65**).

Before handing over the Fitbone Control Set to the patient, set the switches to "Pat." and "Pulse" and put the switch cover back in place.

Thoroughly disinfect the Fitbone Control Set surface with a cloth moistened with 70% alcohol solution before handing over the set to the patient.



PRECAUTION: Please advise your patients not to remove the switch cover from the Control Set and not to touch the switches.

Docking site procedure is optional, at the surgeon's discretion.

DOCKING SITE COMPRESSION AND HEALING

In accordance with the surgeon instructions the patient can continue bone transport to reach the docking site and compress both bone ends until cortical contact is achieved.

The compression protocols vary according to the patient needs and surgeon instruction. However, it is recommended to apply continuous compression until there is radiographical confirmation that cortical contact at the docking site has been achieved.

If needed 1mm compression can be applied until bone ends are touching. It is possible to repeat this procedure over days or weeks to ensure continuous bone to bone contact.

Compression and bone contact will restrict movement at the docking site. By the TN and TLN nails bone compression happens first at the end of excursion.

It is necessary to regularly monitor the docking site until union is achieved. Once the bone is consolidated and union at the docking site is achieved the nail can be exchanged for a trauma nail.

LENGTHENING (OPTIONAL) WITH THE FITBONE TN/TLN

It is possible to perform bone lengthening with the Fitbone TLN nail variant.

Once the bone transport segment reaches the docking site, lengthening starts. Please refer to Fitbone Bone transport nail types for information on sizes and lengthening/transport possibilities.

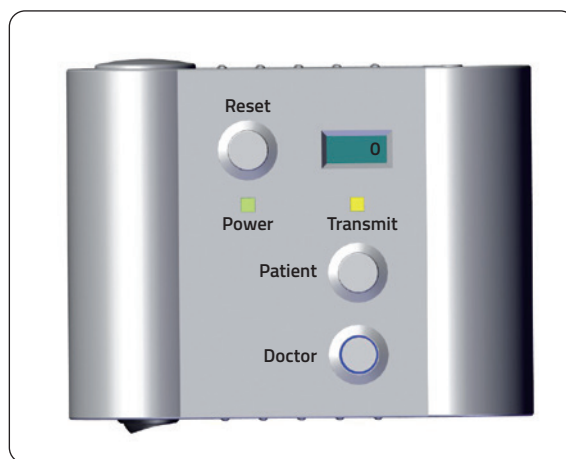

Fig. 64 Doctor mode active



Fig. 65 Final test under sterile conditions



Fig. 66

“Rewind and Go”

Part #	Description
60001644	Fitbone Control Set for activation of intramedullary lengthening nail US plug 115V
60001871	FitboneControl Set for retraction of intramedullary lengthening nail
60000406	Fitbone™ screwdriver SW3.5 cannulated
60000576	Fitbone™ screwdriver SW3.5
60000384	Fitbone™ screw holder M2 L325
99-10013	Allen Wrench 3mm Sterile

If Rewind & Go procedure is needed as per pre-operative plan, the surgery is to be performed before bone consolidation is achieved, in order to prevent an unnecessary osteotomy.

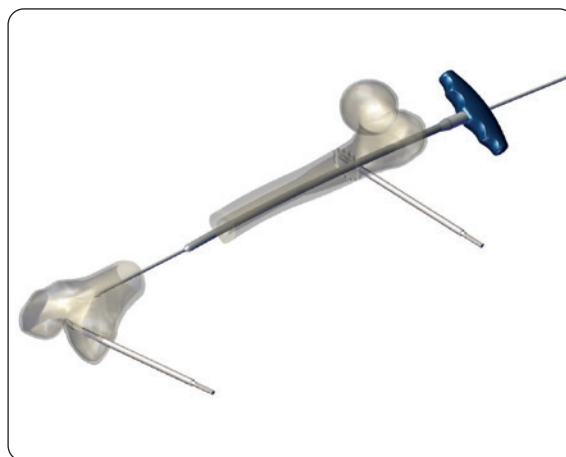

Fig. 67

Rewind and Go refers to resetting the stroke by retraction to its starting position and repositioning the interlocking fixation at the bone segment so that the transport can be continued until docking.

The steps for rewind and go are:

1. External fixator placement (**68b proximal and 69a distal**). It is necessary to hold the transport segment in order to avoid the regenerate from recoiling.
2. Transport segment screw removal (**Fig. 68b and 69a**).
3. Nail retraction. (**Fig. 68c and 69b**) Please follow the instructions given at the "Retraction Control Set Quick Guide"
4. New screw insertion (**Fig. 68c or 69b**).

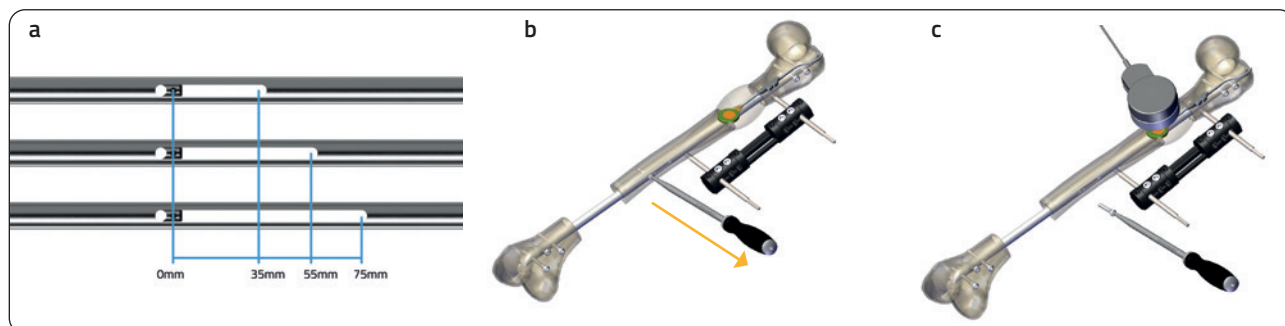

Fig. 68a Available transport strokes, 68b Proximal external fixator placement and screw removal, 68c Nail retraction and screw reinsertion



Fig. 69a Distal external fixator placement and screw removal, 69b Nail retraction and screw reinsertion

For example, a nail with an 80mm transport slot is selected; however, the size of the defect is 100mm. Initial transport can be carried out until the locking screw reaches the end of the transport slot (80mm). The patient is then brought back to the O.R. where the transport locking screw is removed, the motor retracted 20mm or more and a new locking screw is inserted. Transport is then carried out for another 20mm until the docking site is reached."

Please refer to "Quick Guide for Retraction Control Set" for further information."

The Retraction Control Set Components consist of the Control Electronics and a retraction transmitter. The Retraction Control Set Transmitter is larger and heavier than the transmitter of the control set (**Fig. 70**).



Fig. 70

Place the transmitter over the receiver so that they match symmetrically. The portion of the transmitter with the cable exiting should be in the same orientation and directly above the section of the receiver where the cable exits as shown. To ensure retraction, the orientation must be within $\pm 30^\circ$ of this position (green zone), otherwise distraction may occur (red zone) (**Fig. 71**).

Note: If the transmitter is angulated more than $\pm 30^\circ$ (red zone), nail distraction will take place. Failure to place the transmitter and the receiver concentrically will result in a reduced energy transfer and a decrease in retraction speed.

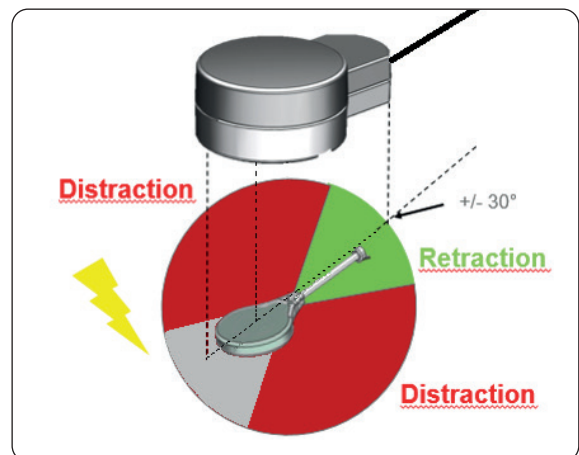

Fig. 71



PRECAUTION: If nail Rewind & Go is needed as per pre-operative plan, always replace the locking screw inserted in the bone transport segment with a new locking screw provided by the manufacturer.



PRECAUTION: During energy transmission, monitor the retraction with the stethoscope and continuous X-ray monitoring. It is also important to consider that Fitbone LOCKING SCREWS inserted in the bone transport segment should be placed at least 10mm away from any newly formed cancellous bone.

FITBONE BONE TRANSPORT AND LENGTHENING SYSTEM – REMOVAL OPT – ANTEGRADE FEMUR

Part #	Description
60001014	Fitbone™ tube T14/13-M
60001028	Fitbone™ cone C13
60001029	Fitbone™ cone C13+
60001030	Fitbone™ cone C13++
60001033	Fitbone™ tube-sinker TS13
60001036	Fitbone™ cone-sinker CS15-13
60001051	Fitbone™ tube T15/14-M
60001064	Fitbone™ tube-sinker TS15
60001060	Fitbone™ cone C15
60001061	Fitbone™ cone C15+
60001062	Fitbone™ cone C15++
60001038	Fitbone™ clamp
60000406	Fitbone™ screwdriver SW3.5 cannulated
60000576	Fitbone™ screwdriver SW3.5
60000384	Fitbone™ screw holder M2 L325
60000419	Fitbone™ reamer D12.0 L100 L480 forehead cutting
60000421	Fitbone™ reamer D13.0 L100 L480 forehead cutting
60000689	Fitbone™ open end wrench SW14/17
60001184	Fitbone™ outrigger TAA
60000218	Fitbone™ space holder TAA
60000310	Fitbone™ connection bolt TAA
60000219	Fitbone™ clamping nut TAA
60000317	Fitbone™ tapping tool
60001039	Fitbone™ K-wire D3mm L280
60000392	Fitbone™ T-handle

Patient positioning

Place the patient in supine position and cover the opposite side completely and the foot of the leg to be operated (Fig. 1).

Nail Marking

Using fluoroscopy, locate the nail and mark the position of the nail using a skin marker. The skin marking will aid orientation and positioning during surgery (Fig. 2).

Distal, transport and blocking screws removal

Locate the distal screws under fluoroscopy and make a skin incision to gain access. If required, use a 5–8mm chisel to remove any bone obstructing access to the screws (Fig. 3).

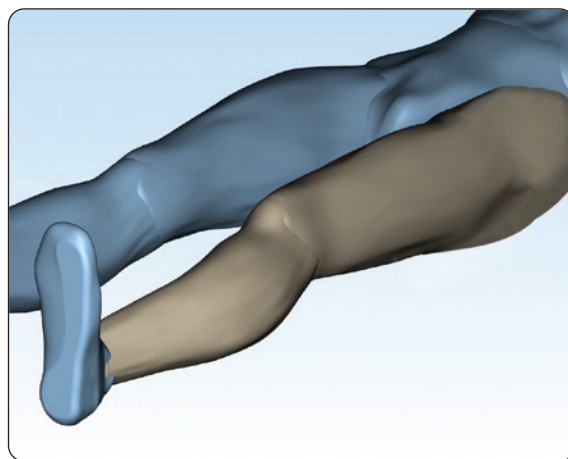

Fig. 1 Patient positioned

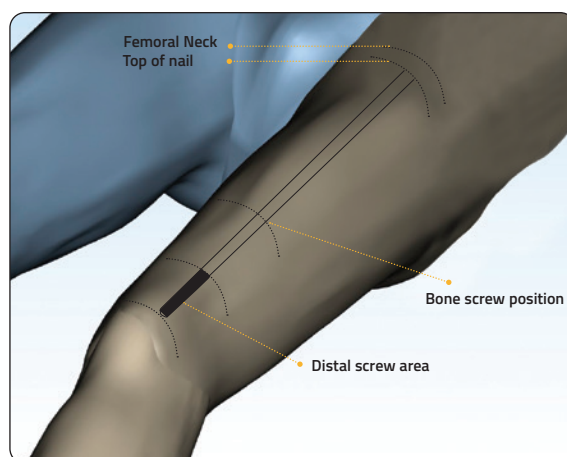

Fig. 2 Nail marking



Fig. 3 Distal and transport screws location and skin opening

Engage the first screw with the screwdriver SW3.5 cannulated and the screw holder M2 L325 and remove (Fig. 4). Repeat the same process to remove the remaining distal screws.

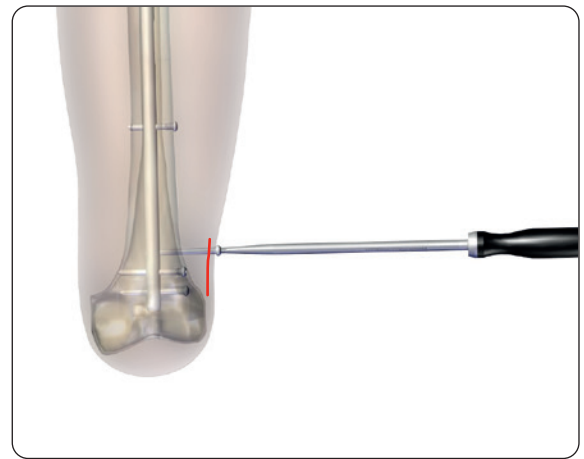

Fig. 4 Distal screw removal

Locate the transport screw under fluoroscopy and make a skin incision to gain access. Repeat the same process to remove it (Fig. 5).

Remove all blocking screws if present.

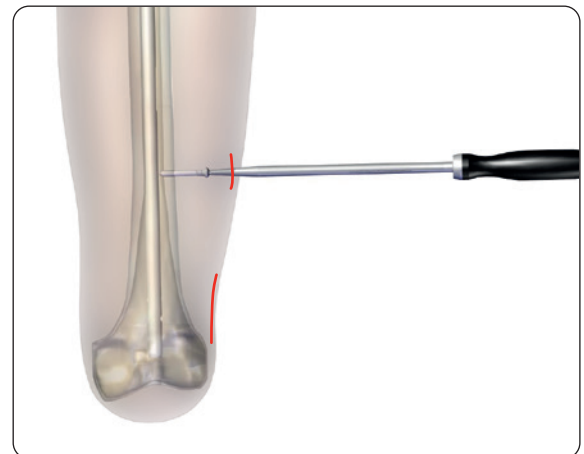

Fig. 5 Transport locking screw removal

Receiver removal

Locate and palpate the receiver on the skin and mobilize it in order to loosen any soft tissue that might be attached to it.

Make a 20mm skin incision along the scar of the receiver skin pocket (Fig. 6).

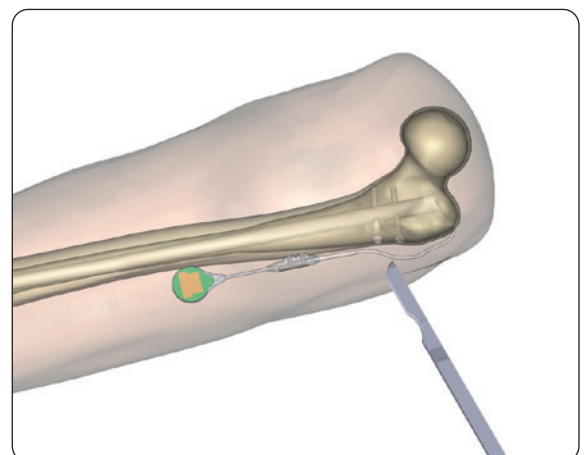

Fig. 6 Lateral cut

Locate and palpate the receiver under the skin (**Fig. 7**).

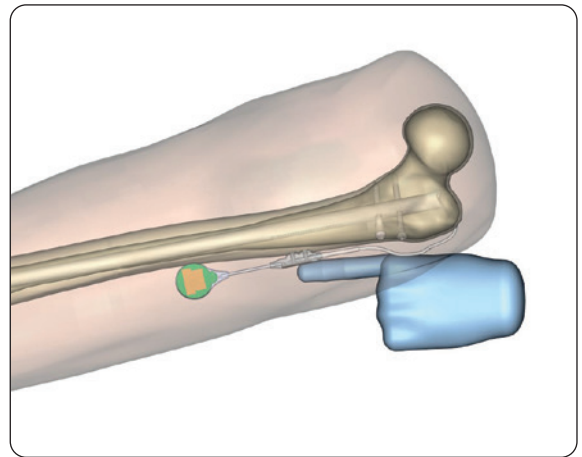

Fig. 7 Receiver location

Mobilize the coupling and remove from the skin pocket (**Fig. 8**).

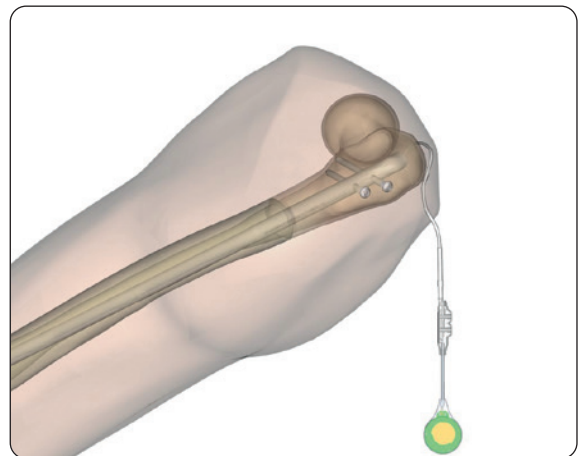

Fig. 8 Receiver extraction

Cut the cable proximally before the thicker part of the silicone (**Fig. 9 and 10**).

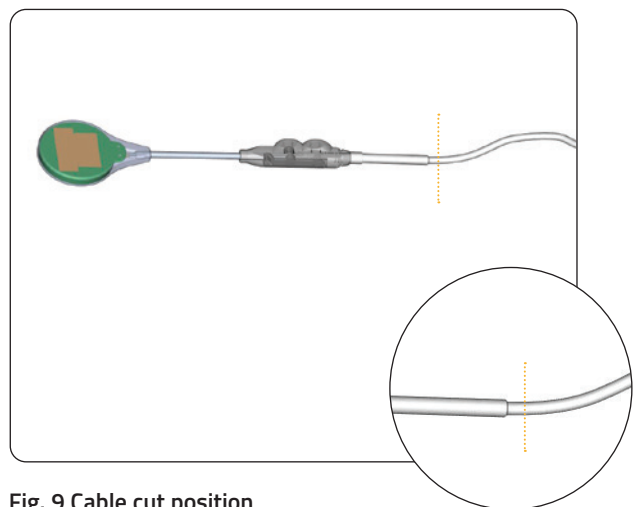

Fig. 9 Cable cut position

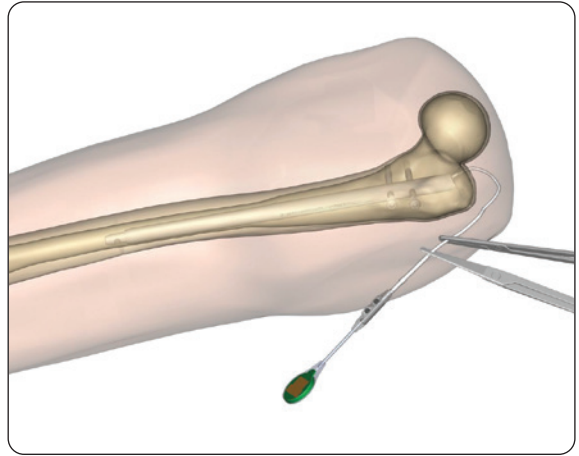

Fig. 10 Cutting the cable

Remove the coupling and the receiver with a Kocher clamp.
Secure the remaining part of the cable with a clamp (**Fig. 11**).

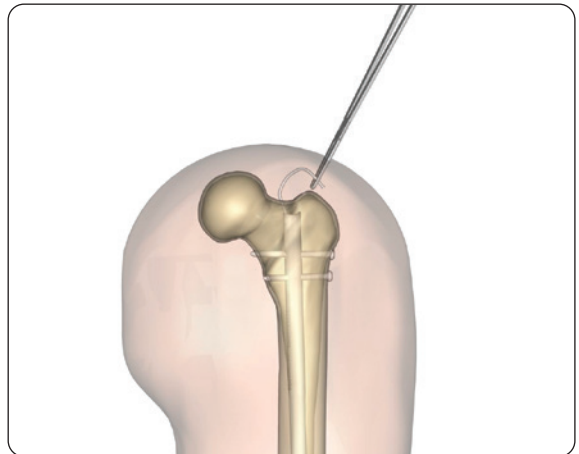

Fig. 11 Fixing the cable with a clamp

Proximal screw removal

Remove one of the proximal screws (**Fig. 12**).

Do not remove the clamp from the cable.

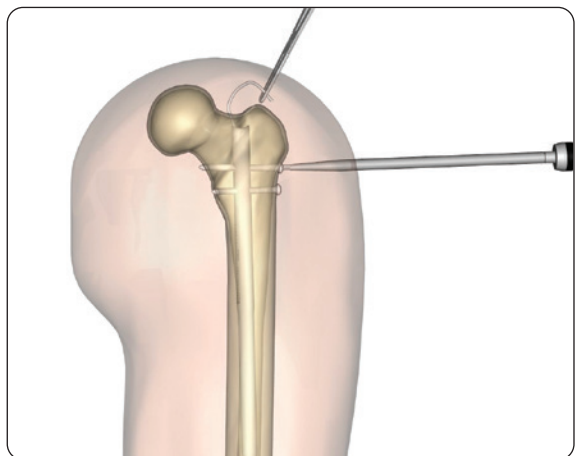

Figure 12 First proximal screw removal

Do not remove both proximal screws (**Fig. 13**).

Make a 20mm skin incision along the scar of the insertion point. Find the position of the nail inside the bone. If required, use fluoroscopic guidance to assist determining nail location.

Remove newly formed bone from the entry point with a small chisel.

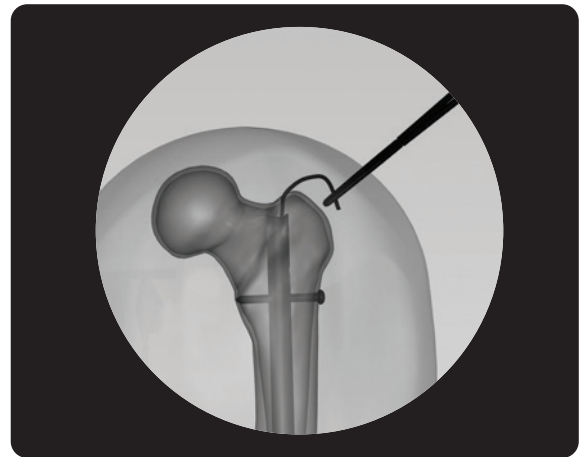

Fig. 13 Cable position after removing the cable connection

Cone placement

Place a kirschner wire central to the top of the nail (**Fig. 14**).

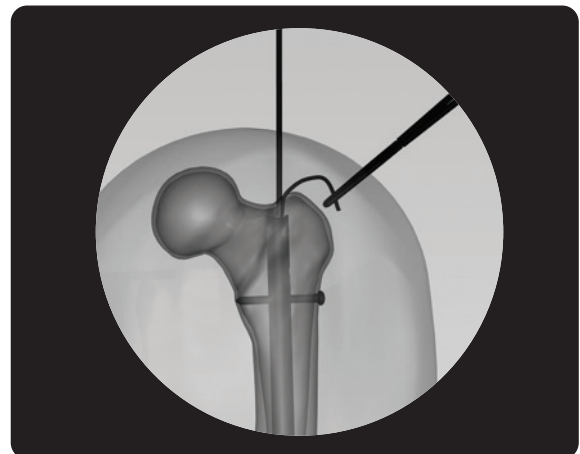

Fig. 14 Kirschner wire position

Introduce the cone C13 or C13+ over the kirschner wire and into the bone by using the cone sinker CS13-15 for 11mm nails. For 13mm nails use cone C15, C15+ or C15++. To ensure stability, the teeth of the cone should be within the bone, not touching the Fitbone (**Fig. 15**).

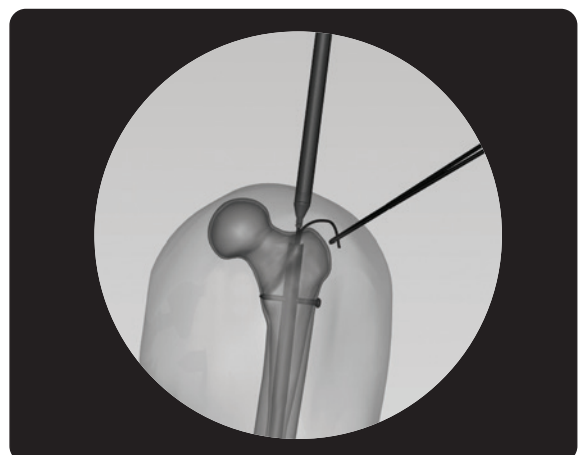

Fig. 15 Cone positioning

Tube placement

Insert the tube T14/13-S or M with the tube sinker TS13 when extracting an 11mm nail. In case of extracting a 13mm nail insert the tube T 15/14-S or M with the tube sinker T15. Insert to a depth of 5-10mm (**Fig. 16**).

Take care not cut the cable with the tube and do not touch the Fitbone with either the cone or the tube because that will damage the instruments.

Remove the cone and kirschner wire.

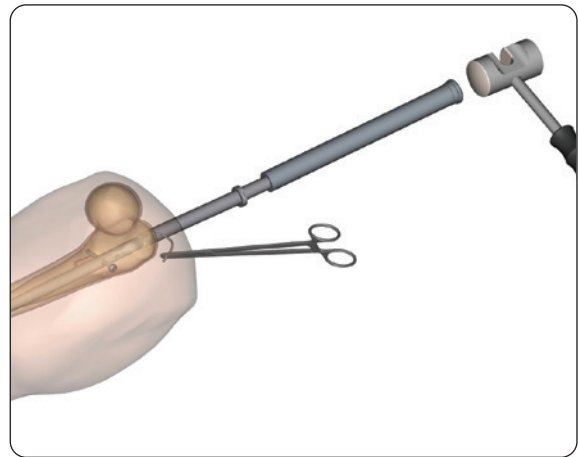

Fig. 16 Working tube insertion

Remove the clamp and use the front cutting reamer 12mm (reamer D12.0 L100 L480 forehead cutting) for 11 mm nails or the front cutting reamer 13mm (reamer D13.0 L100 L480 forehead cutting) for 13mm nails to ream up to the cable by hand (**Fig. 17**).

In some instances the reamer may capture the cable and advance into the tube.

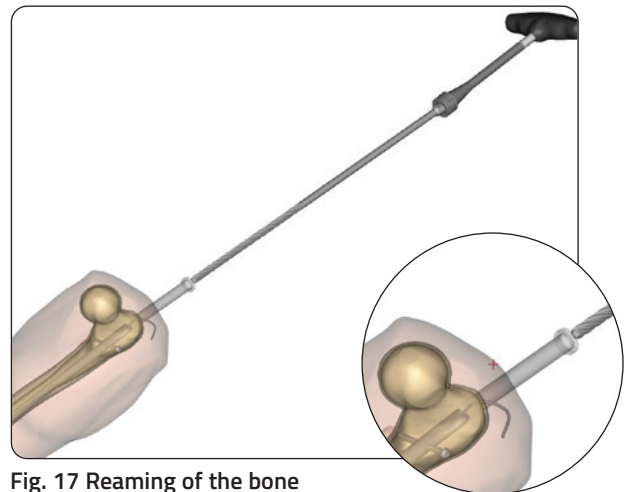

Fig. 17 Reaming of the bone

Otherwise

Use an arthroscopic hook to retrieve the cable (**Fig. 18**).

Use the probe / arthroscopic hook to advance the cable through the tube and secure a suture to the external portion of the cable.

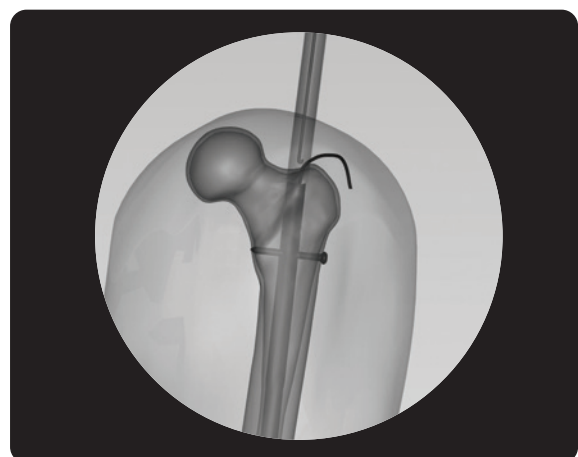

Fig. 18 Catching the cable with the arthroscopic hook

Connecting the nail and connection bolt

Pass the suture which is connected to the cable through the connection bolt (Fig. 19).

An ACL guidewire can be used to aid the passing of the suture.

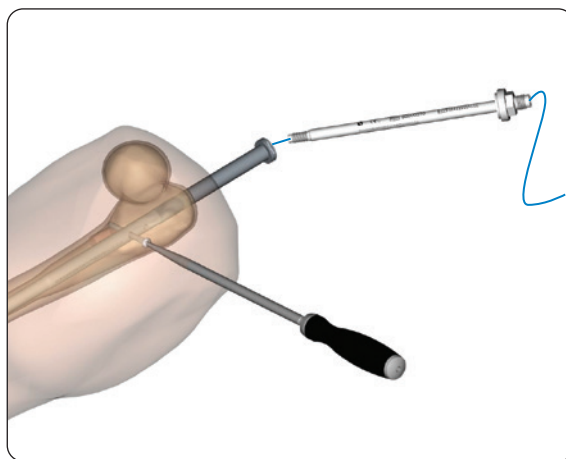

Fig. 19 Passing the cable through the Connection Bolt

Firmly attach the connection bolt to the nail, before securing the tapping tool to the connection bolt (Fig. 20).

Check under X-ray if the connection bolt is inserted into the Fitbone longitudinal aligned AP and lateral.

If you have any problems threading the connection bolt to the nail, rinse and vacuum at the connection part to remove any bone debris that could remain there

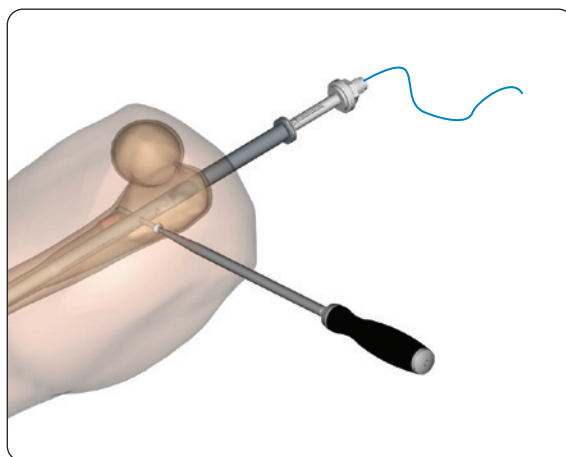

Fig. 20 Fixing the nail with the Connection Bolt

Nail removal

Partially remove the final locking screw, ensuring the nail can pass upon extraction. Do not fully remove the screw, as should the connection to the nail become compromised, the screw can be reinserted to secure the nail once again (Fig. 21).

Use the slotted mallet (not a standard hammer) to advance the nail out of the bone. A combination of high repetitions and light to moderate force is advised to avoid damage to the knee joint and tube (Fig. 21).



WARNING: Never use a hammer to drive or remove the Fitbone Nail into/ from the medullary cavity since this could damage the implant.

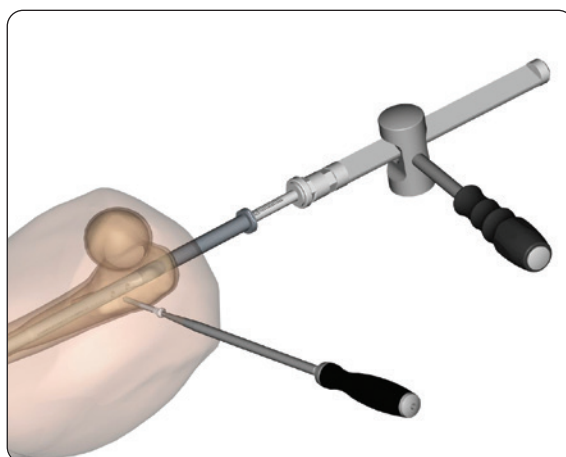

Fig. 21 Disengaging the final screw from the nail and slap hammer functioning

Upon nail extraction, fully remove the final locking screw **(Fig. 22)**.

Flush the wound to remove any debris and confirm under fluoroscopy.

Perform a final check under fluoroscopy to ensure the site is free from debris.

Perform a layered closure of the extraction site.

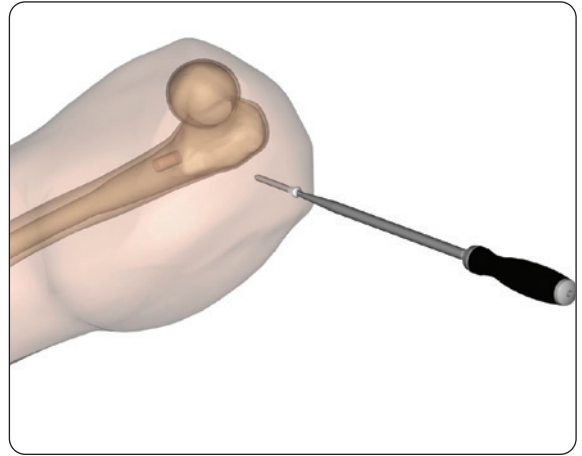

Fig. 22 Removing the screw

Please refer to the “Instructions for Use PQFBT, PQFBP and PQFBR” supplied with the product for specific information on indications for use, contraindications, warnings, precautions, possible adverse events, MRI (Magnetic Resonance Imaging) safety information and sterilization.

Products may not be available in all markets because product availability is subject to regulatory and/or medical practices in individual markets. Please contact your Orthofix representatives if you have any questions about the availability of Orthofix products in your area.



*** Manufactured by:**

ORTHOFIX Srl
Via Delle Nazioni 9, 37012 Bussolengo
(Verona), Italy
Tel.: +39 045 6719000
Fax: +39 045 6719380

*If not otherwise indicated on the product label.

Orthofix products or services referenced herein are trademarks or registered trademarks of Orthofix SRL and its group of companies. All rights reserved.

Distributed by:

Rx Only